

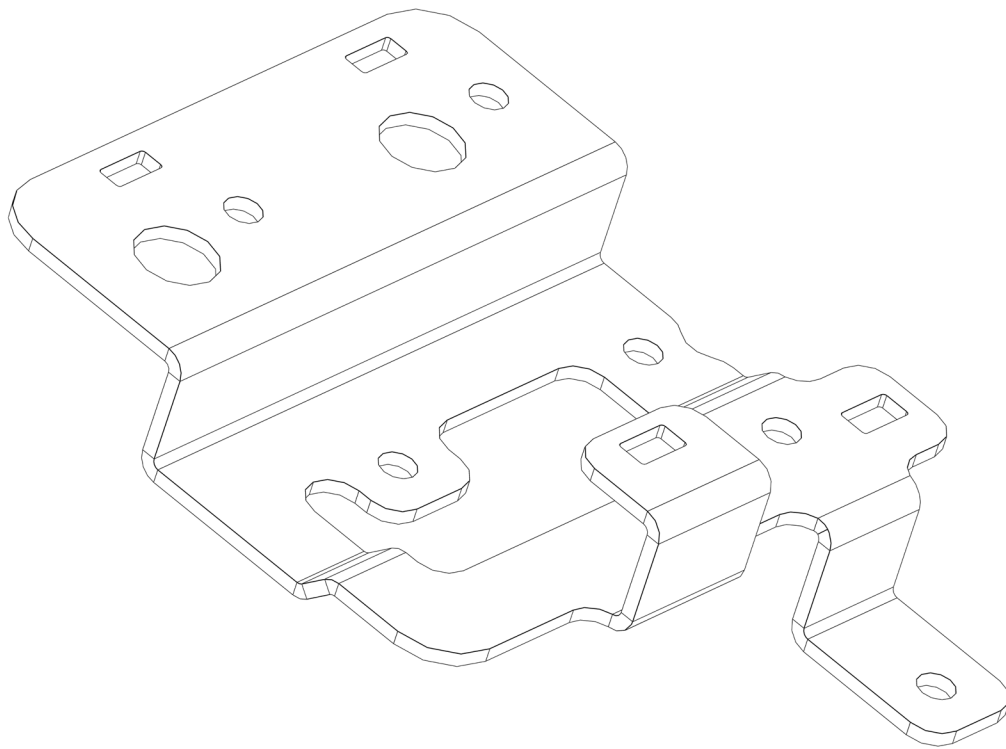

6TH GEN BRONCO ACC RELOCATION BRACKET

INSTALL INSTRUCTIONS



Please read the mounting instructions below carefully before attempting to install.

Check out the install video on the product page for more detailed information.

Thank you for purchasing from JcROffroad! Checkout our website, www.jcroffroad.com for other great off-road products. Be sure to rate and review our product online. If you have any questions or are missing parts, please don't hesitate to call us at 269-353-1184!

INCLUDED PARTS

1x

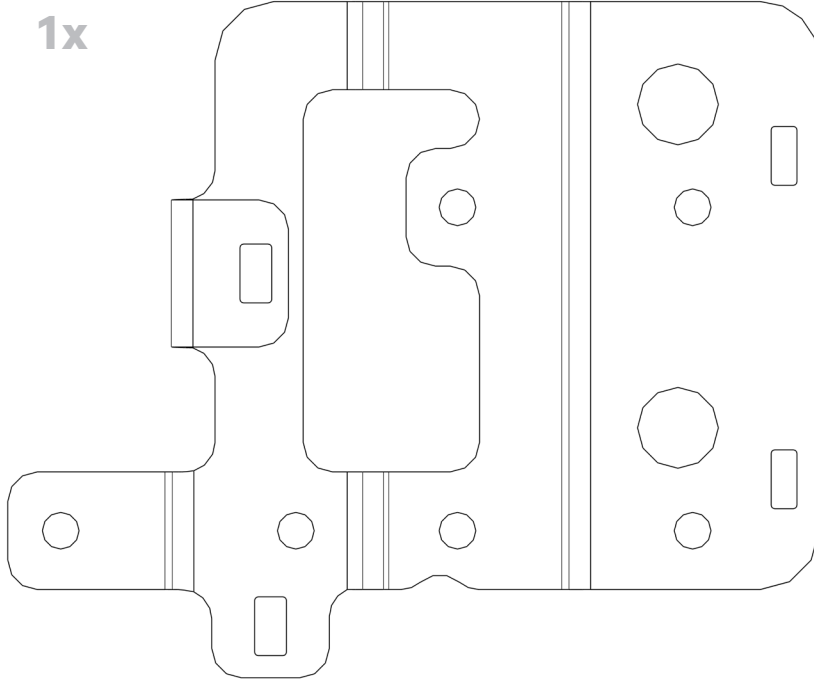

INCLUDED HARDWARE

3x

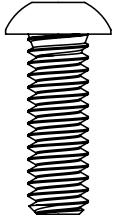

1/4"-20 x 3/4"
Button Head

3x

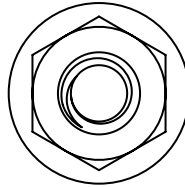

1/4"-20
Serr. Flange Nut

ASSEMBLY

- 1 Once you have your bumper removed from the vehicle, start by popping off the plastic cover to the ACC moduel. To do so, pull out on the top corners to release the clips and then pivot back. There are then three exposed bolts in an L shape you then remove with an impact or wrench with an 8mm socket.

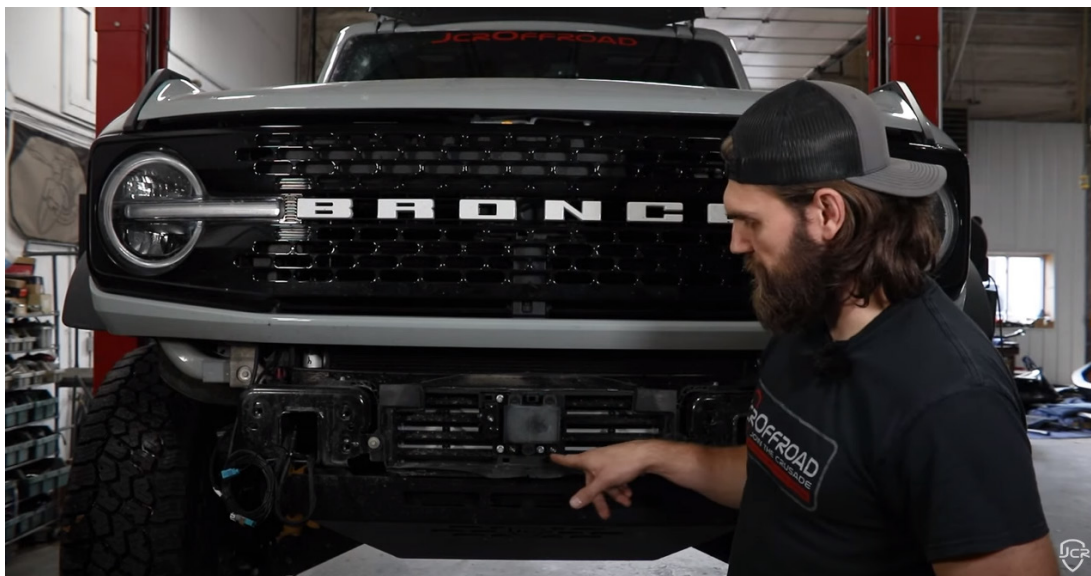

ASSEMBLY

- 2 Once the bolts are removed, pop out the wire harness from the bracket by applying pressure to the thumb tab. Once that bracket is removed, you then remove the four bolts in each corner with an 8mm socket for the bottom ones and wrench for the top.

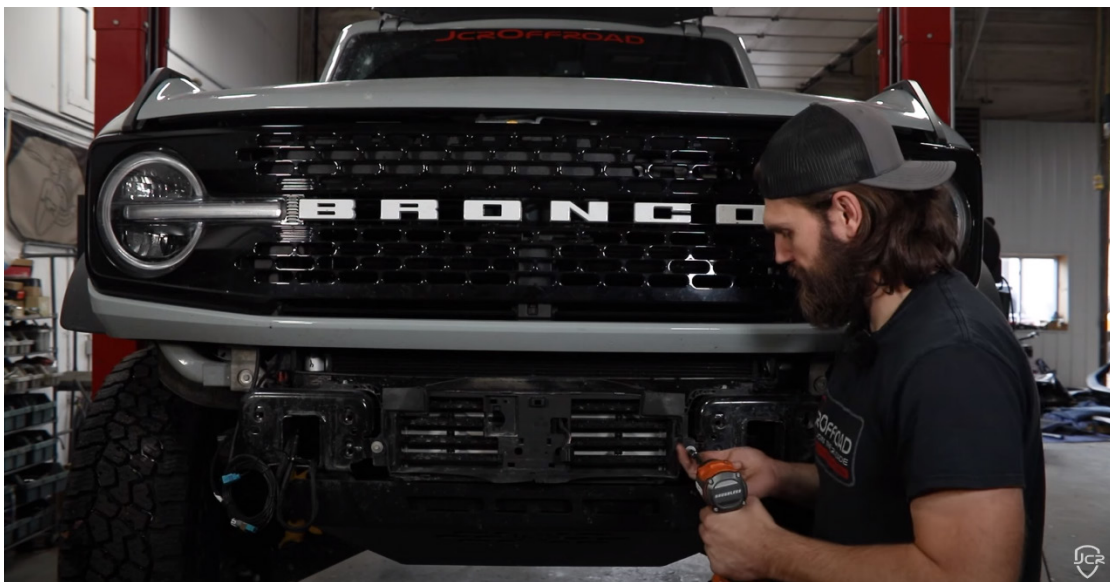
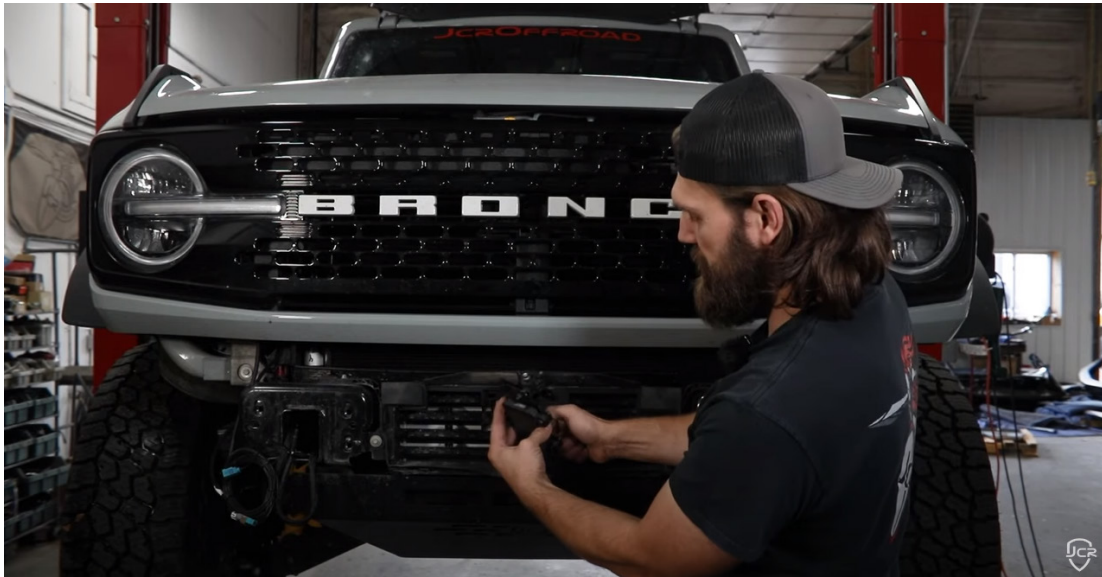

ASSEMBLY



- 3** After that hardware is removed, lift the entire assembly up and then flip it around to remove the four plastic mounting clips that hold the wire harness in place. You may want to use a pry tool or a flathead screwdriver if available.



ASSEMBLY

- 4 Once the harness is removed, start to clip the harness back into the assembly but one spot over from the original. You should only clip back into three places, leaving some slack on the end needed for our relocation bracket.



- 5 Once the harness is clipped back on, and the extra slack hanging out of the front, then place that assembly back into its original place. You then re-install the four factory bolts that you removed to keep it in place.



ASSEMBLY

- 6 Once the assembly is bolted back into place, take the provided bracket and route the extra slack from the harness through the center cut out on the bracket. Then line up the holes on the bracket to the factory holes in the center of that assembly and loosely re-install the factory 8mm bolts to hold the bracket in place.



- 7 When the bracket is loose in place, take the factory module and plug it back in to the wire harness that is hanging through our bracket.



ASSEMBLY

- Take the provided button heads and use them to loosely install the module to our re-location bracket through the three hole cut outs with the provided serrated flange nuts. Once you have the bracket in place and all the bolts started, you can then tighten them up with a 5/32" hex head.

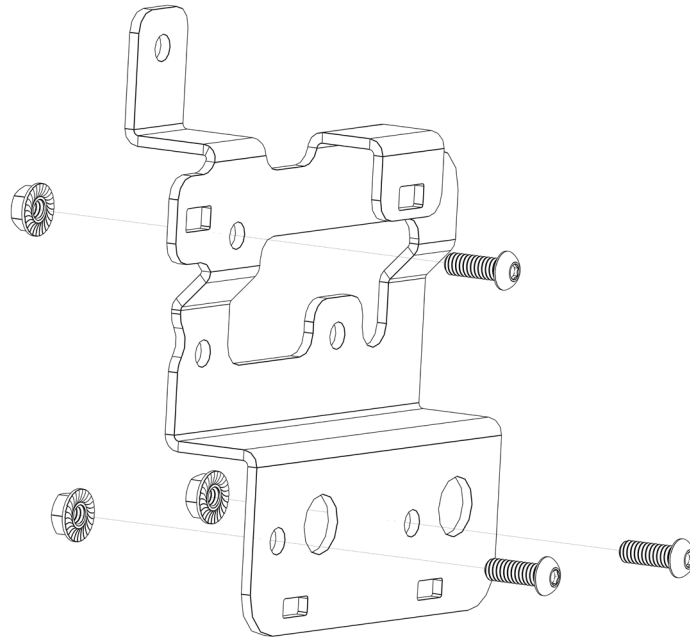

- Finally, to complete your install pop back on your plastic cover piece by sliding into the bottom slots first and then snapping back in the top once it is aligned.

