



TABLE OF CONTENTS

6TH GEN BRONCO
PRERUNNER BOLT-ON HOOP.....2

6TH GEN BRONCO
BULL BAR BOLT-ON HOOP.....6



6TH GEN BRONCO PRERUNNER BOLT-ON HOOP

INSTALL INSTRUCTIONS

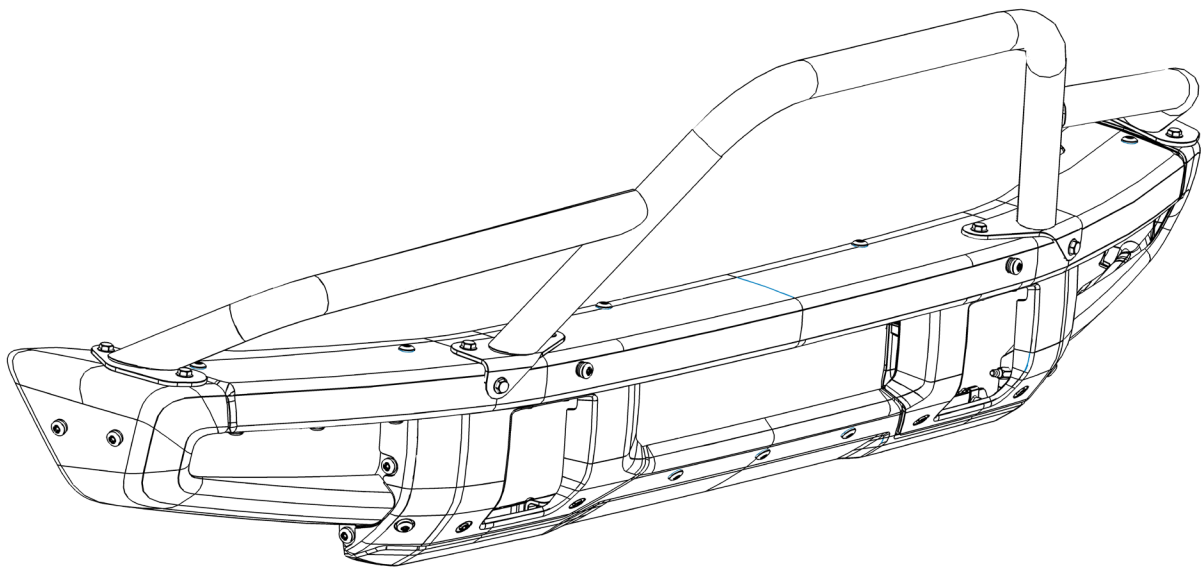

Please read the mounting instructions below carefully before attempting to install.

Be sure to check out the install video on the product page, if available.

Thank you for purchasing from JcROffroad! Checkout our website, www.jcroffroad.com for other great off-road products. Be sure to rate and review our product online. If you have any questions or are missing parts, please don't hesitate to call us at 269-353-1184!

INCLUDED HARDWARE

10x

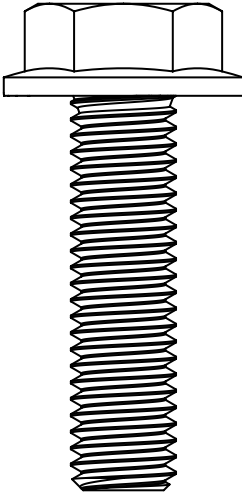

M8 X 30mm
Flanged Hex Head

INCLUDED PARTS

1x

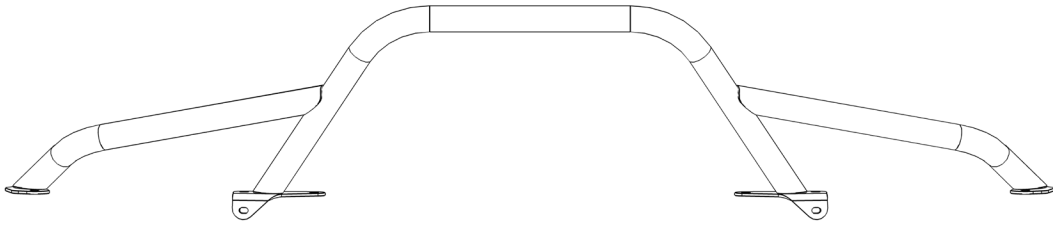

ASSEMBLY

- 1 Start by removing the ten bolts circled below.

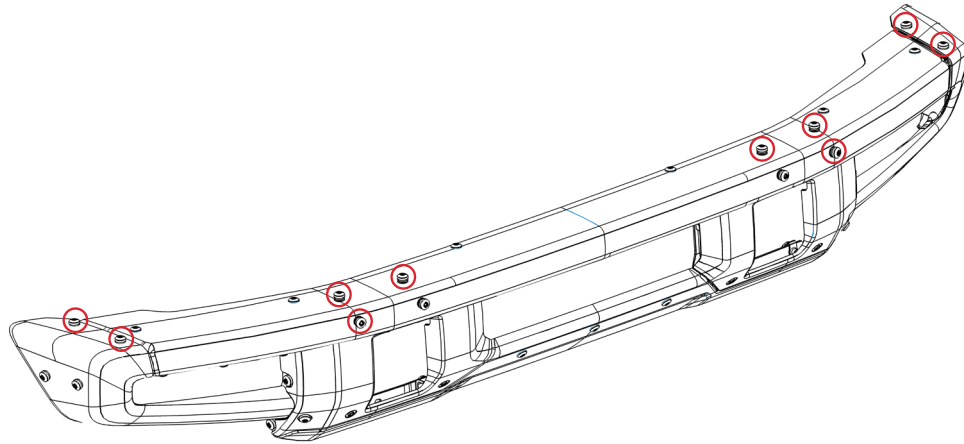

- 2 Once those are out of the way, place the tube onto the bumper and install it into the holes you just cleared using the provided M8 bolts. The easiest way to do this is to start with the center bolts and work your way out. That way it is much simpler to line up each end. If you are still struggling to get everything lined up, you can adjust the position of the caps on either end of the bumper as well.

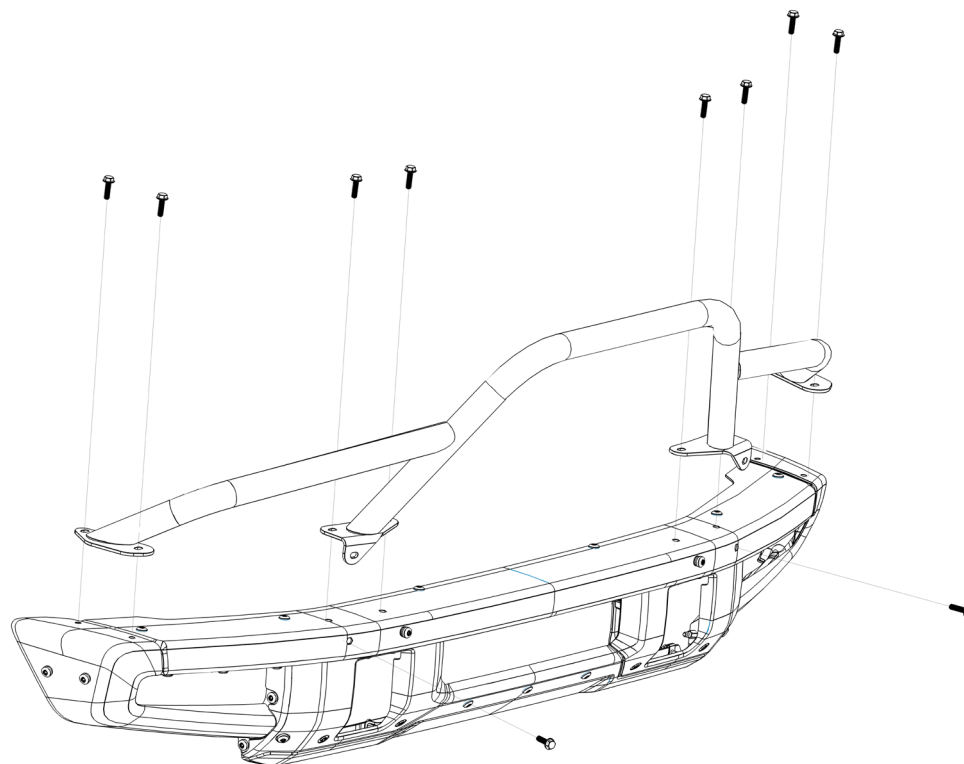



6TH GEN BRONCO BULL BAR BOLT-ON HOOP

INSTALL INSTRUCTIONS

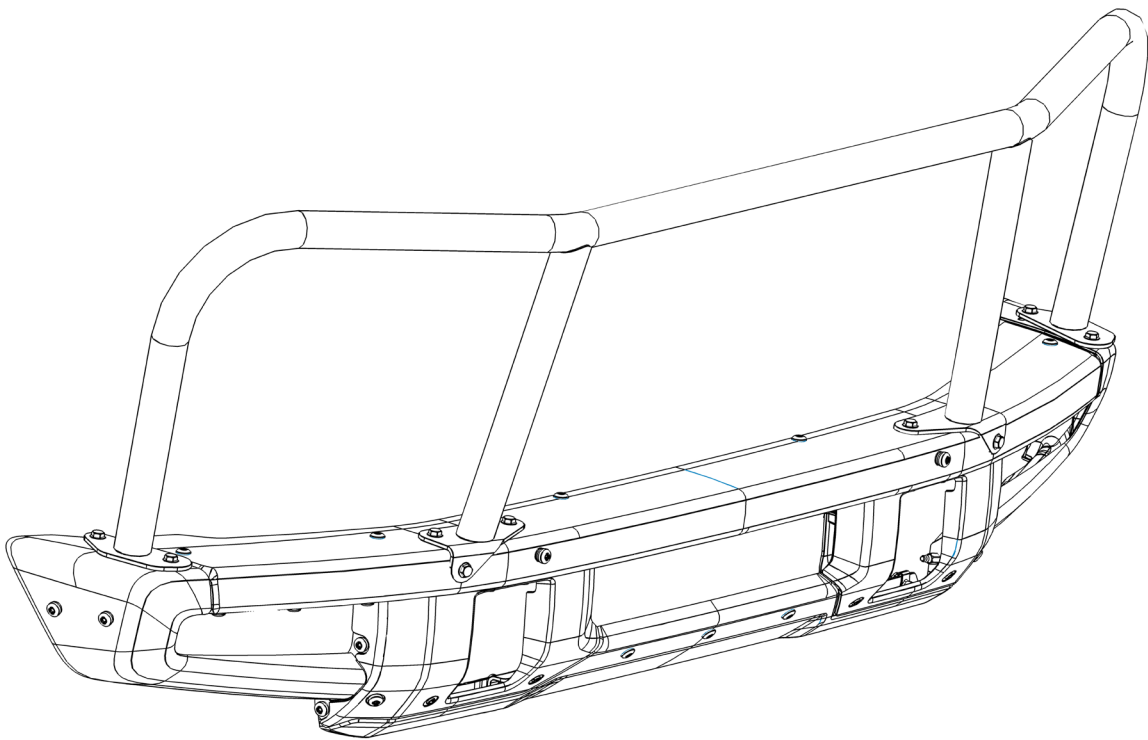

Please read the mounting instructions below carefully before attempting to install.

Be sure to check out the install video on the product page, if available.

Thank you for purchasing from JcRoffroad! Checkout our website, www.jcroffroad.com for other great off-road products. Be sure to rate and review our product online. If you have any questions or are missing parts, please don't hesitate to call us at 269-353-1184!

INCLUDED HARDWARE

10x

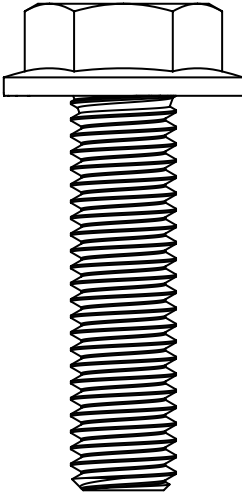

M8 X 30mm
Flanged Hex Head

INCLUDED PARTS

1x

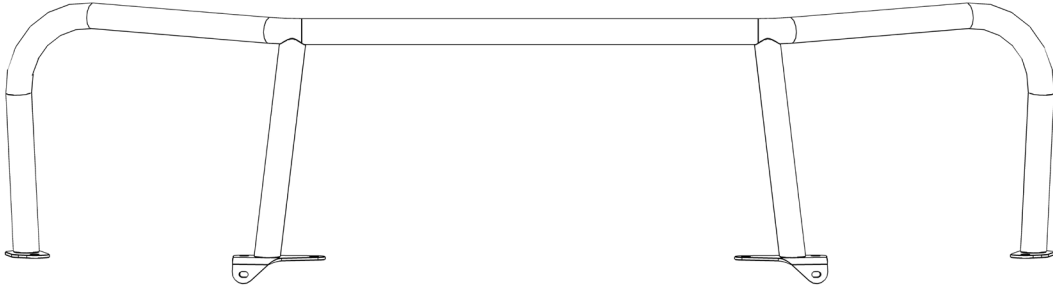

ASSEMBLY

- 1 Start by removing the ten bolts circled below.

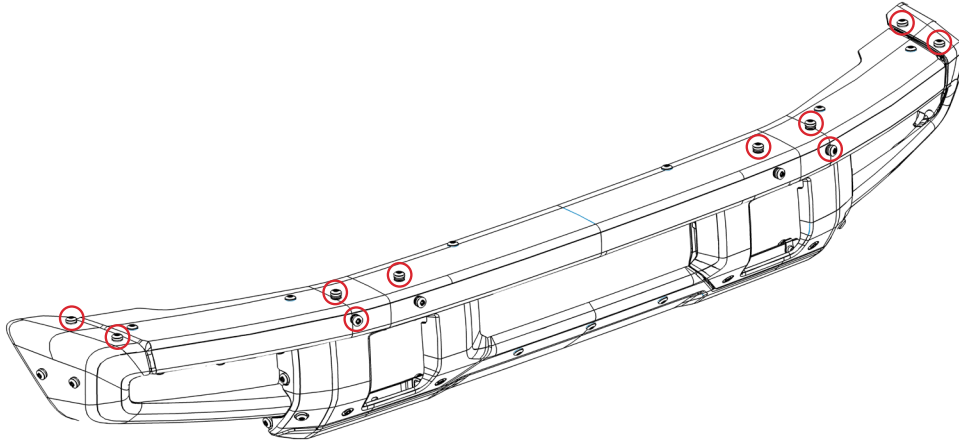

- 2 Once those are out of the way, place the tube onto the bumper and install it into the holes you just cleared using the provided M8 bolts. The easiest way to do this is to start with the center bolts and work your way out. That way it is much simpler to line up each end. If you are still struggling to get everything lined up, you can adjust the position of the caps on either end of the bumper as well.

