



TABLE OF CONTENTS

6TH GEN BRONCO SIDE ACCESSORY PANEL.....	2
JL/JK SIDE ACCESSORY PANEL.....	9
XJ SIDE ACCESSORY PANEL.....	15



6TH GEN BRONCO

SIDE ACCESSORY PANEL

INSTALL INSTRUCTIONS

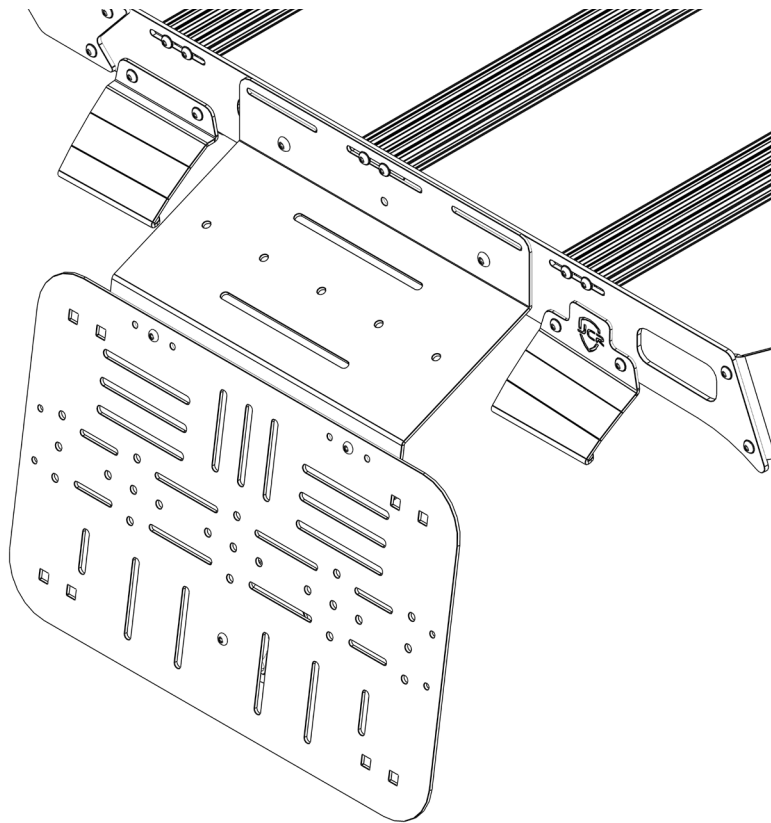

Please read the mounting instructions below carefully before attempting to install.

Be sure to check out the install video on the product page, if available.

Thank you for purchasing from JcROffroad! Checkout our website, www.jcroffroad.com for other great off-road products. Be sure to rate and review our product online. If you have any questions or are missing parts, please don't hesitate to call us at 269-353-1184!

INCLUDED HARDWARE

2x

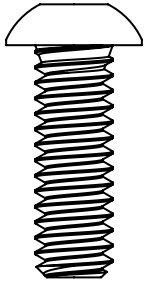

1/4"-20 X 3/4"
Button Head

1x

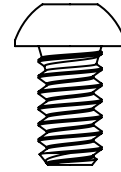

1/4"-20 X 3/8"
Button Head

2x

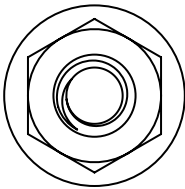

1/4"-20
Serr. Flange Nut

2x

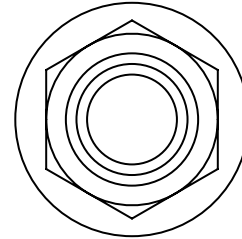

5/16"-18
Flanged Nylock Nut

2x

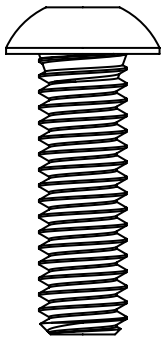

5/16"-18 X 1"
Button Head

INCLUDED PARTS

1x

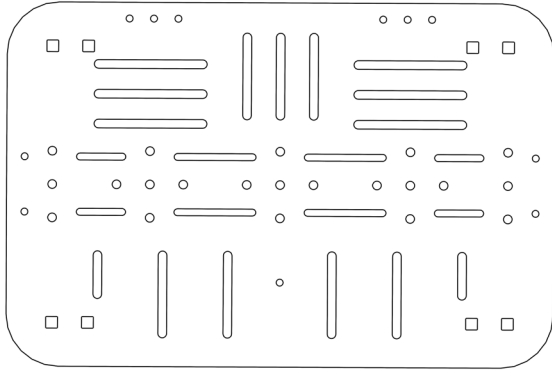

1x

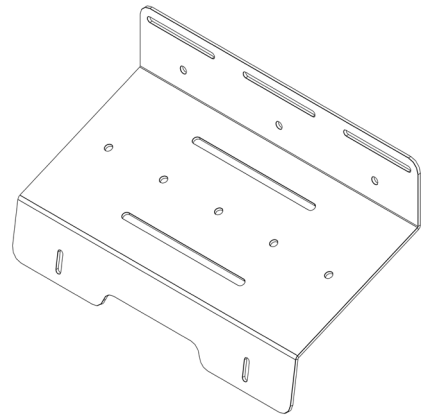

1x

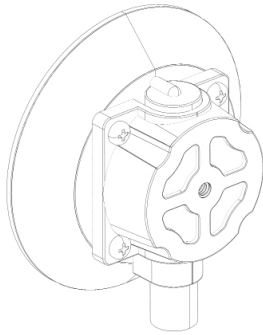

2x

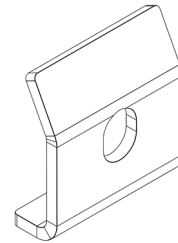

INSTALLATION

- 1** Start by loosely installing the mounting bracket onto your roof rack. To do this, determine which cross bars you must mount to in order to position the panel over the rear window. Then, remove the bolts from the one end of the crossbars and use those bolts to mount the bracket to the side of the roof rack and back into the bars. For the four door Bronco, you will only mount the center slot to the second cross bar from the rear. For the two door, you will mount the outer slots to the second and third crossbars from the rear.

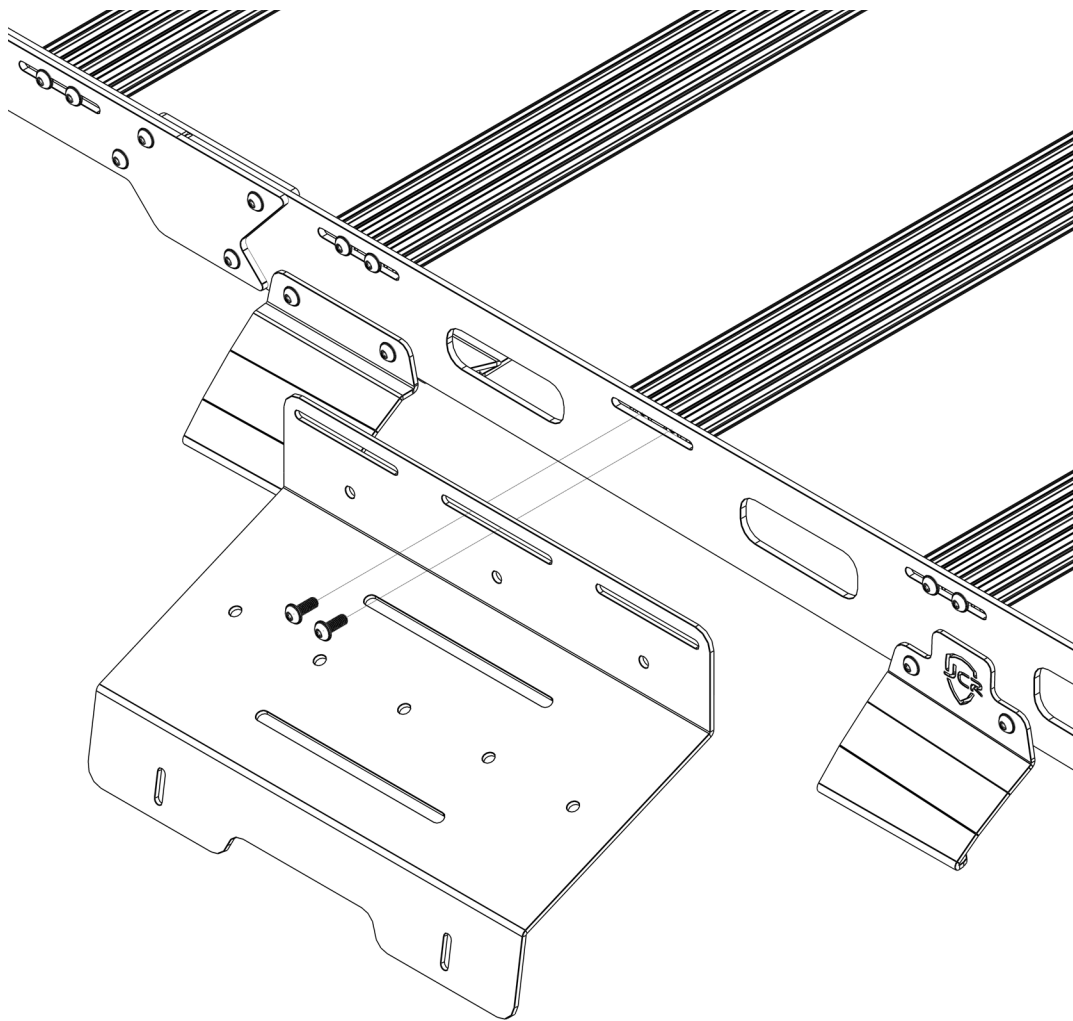

INSTALLATION

- 2** Next, mount the suction cup on the backside of the panel using the 1/4"-20 X 3/8" bolt. Make sure the button is pointing straight down.

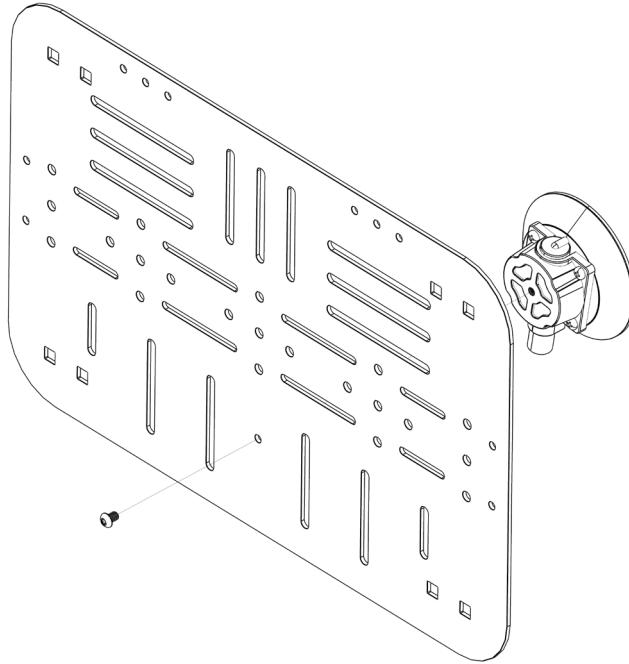

- 3** Next, loosely mount the panel to the outside of the mounting bracket using the 1/4"-20 X 3/4" bolts and 1/4"-20 serr. flange nuts.

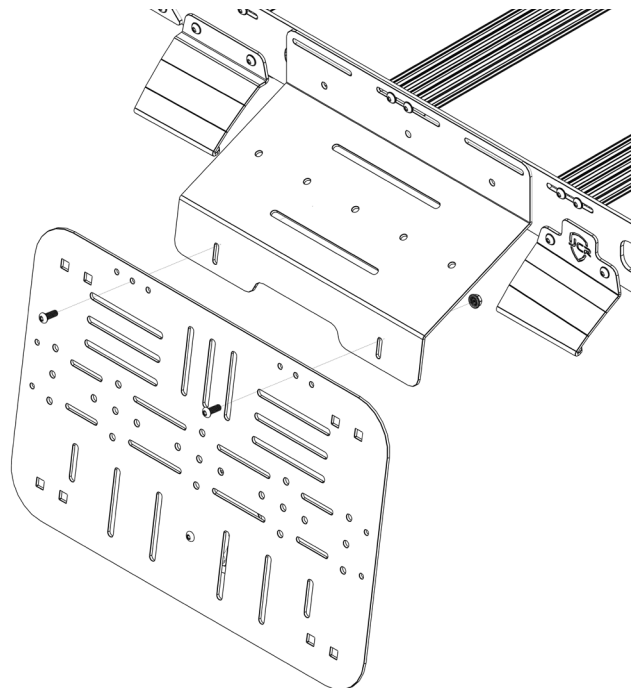

INSTALLATION

- 4 Next, adjust the position of the mounting bracket until the panel is centered in the window. Then, push the bottom against the window and push the button on the bottom of the suction cup to stick it to the window. You can then tighten all the hardware.

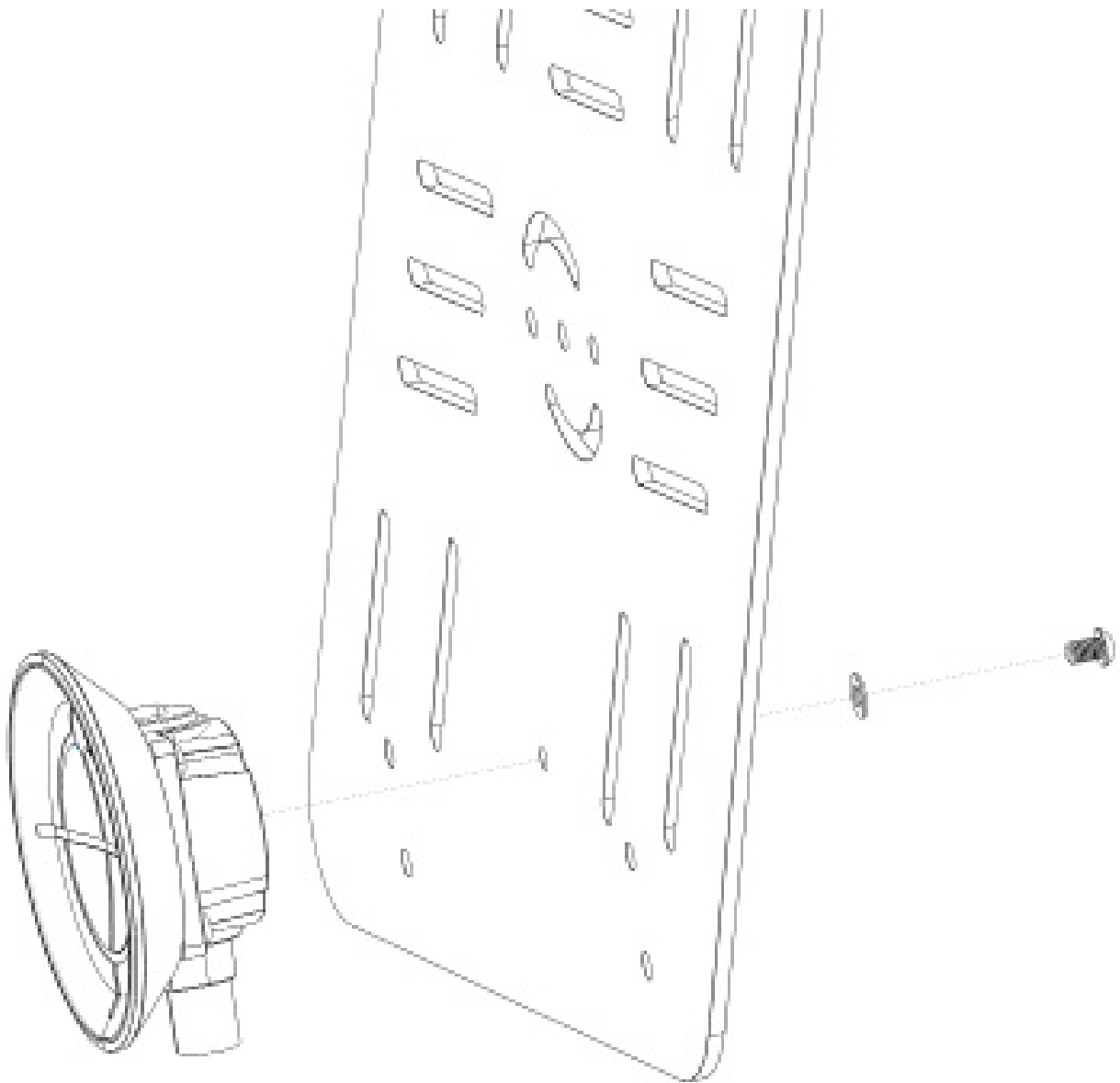

INSTALLATION

- 5** Finally, use the small C shaped brackets to clamp the bottom of the mounting bracket to the rack. To do this, bolt the bracket in on the inside of the side rail, through one of the holes in the bracket that lines up with the cutouts in the roof rack using a 5/16"-18 X 1" bolt with a 5/16"-18 flanged nylock nut on the inside. The bracket should be oriented so that the 90 degree bend is towards the top. That flange should sit flat against the inside face of the mounting bracket while the other end should sit against the inside face of the side rail. On the four door Bronco, you will need to use two of these brackets, one in each of the outer holes. On the two door, you will only need to use one in the center hole.

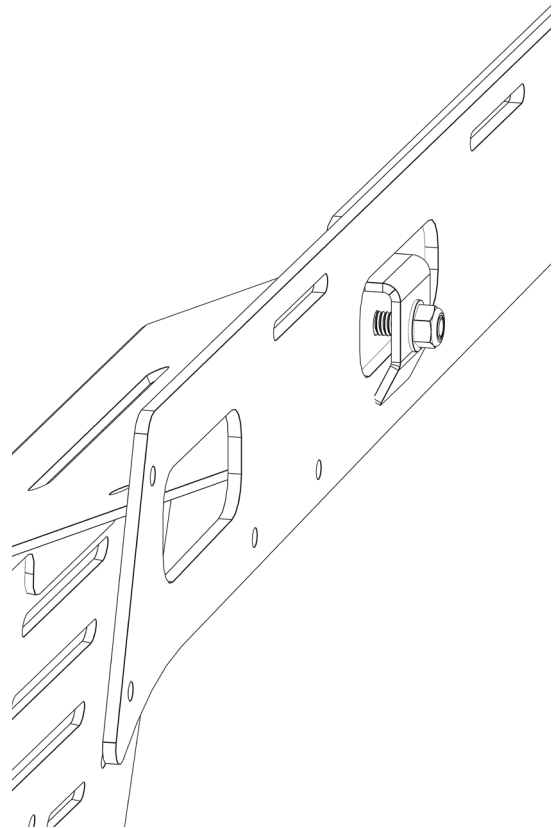
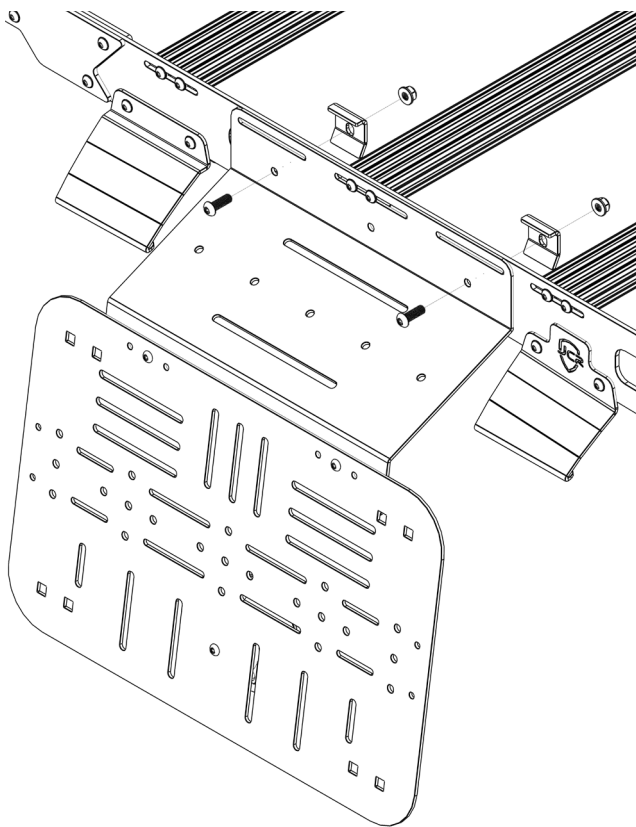



JL/JK

SIDE ACCESSORY PANEL

INSTALL INSTRUCTIONS

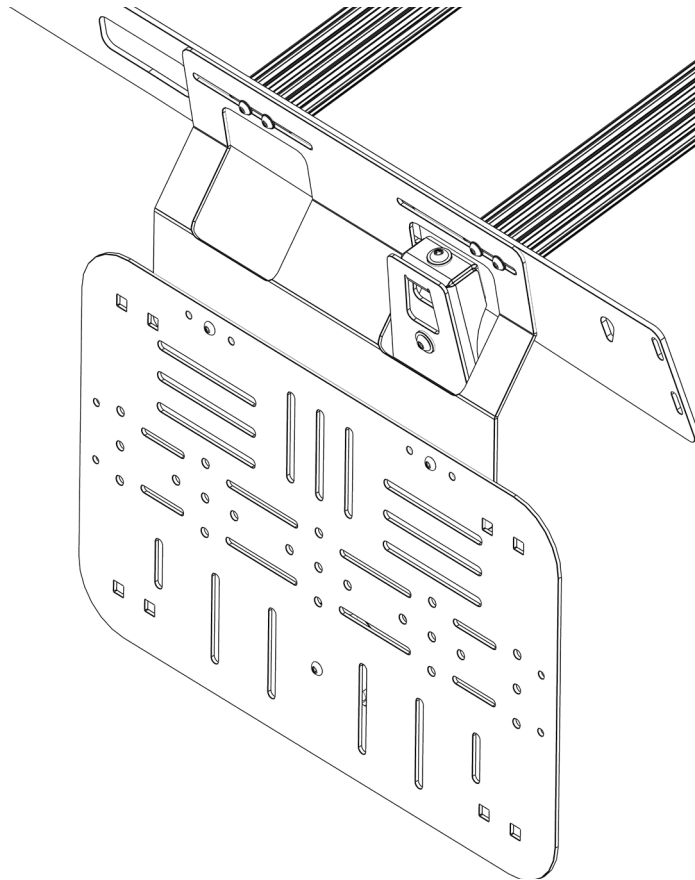

Please read the mounting instructions below carefully before attempting to install.

Be sure to check out the install video on the product page, if available.

Thank you for purchasing from JcROffroad! Checkout our website, www.jcroffroad.com for other great off-road products. Be sure to rate and review our product online. If you have any questions or are missing parts, please don't hesitate to call us at 269-353-1184!

INCLUDED HARDWARE

2x

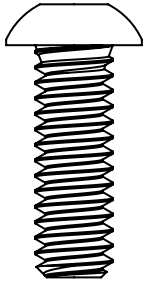

1/4"-20 X 3/4"
Button Head

1x

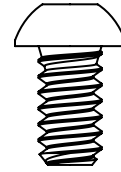

1/4"-20 X 3/8"
Button Head

2x

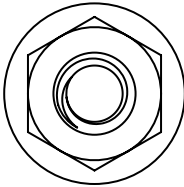

1/4"-20
Serr. Flange Nut

INCLUDED PARTS

1x

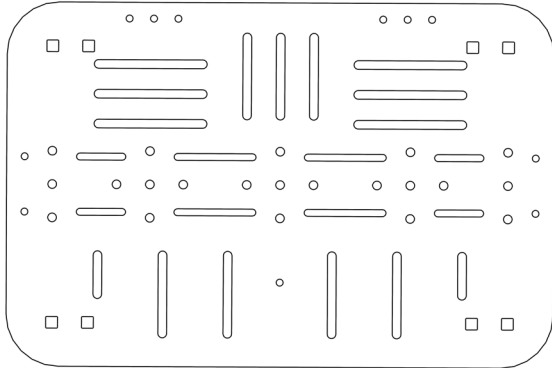

1x

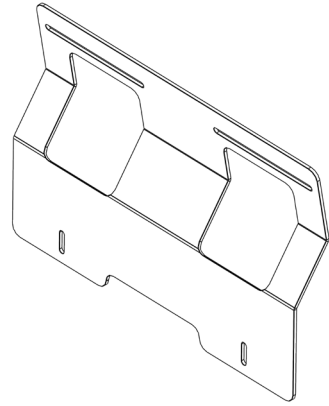

1x

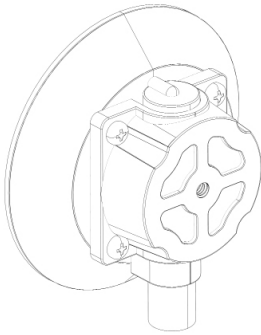

INSTALLATION

- 1 Start by loosely installing the mounting bracket onto your roof rack. To do this, remove the bolts from the one end of the two rear most crossbars and use those bolts to mount the bracket to the side of the roof rack and back into the bars.

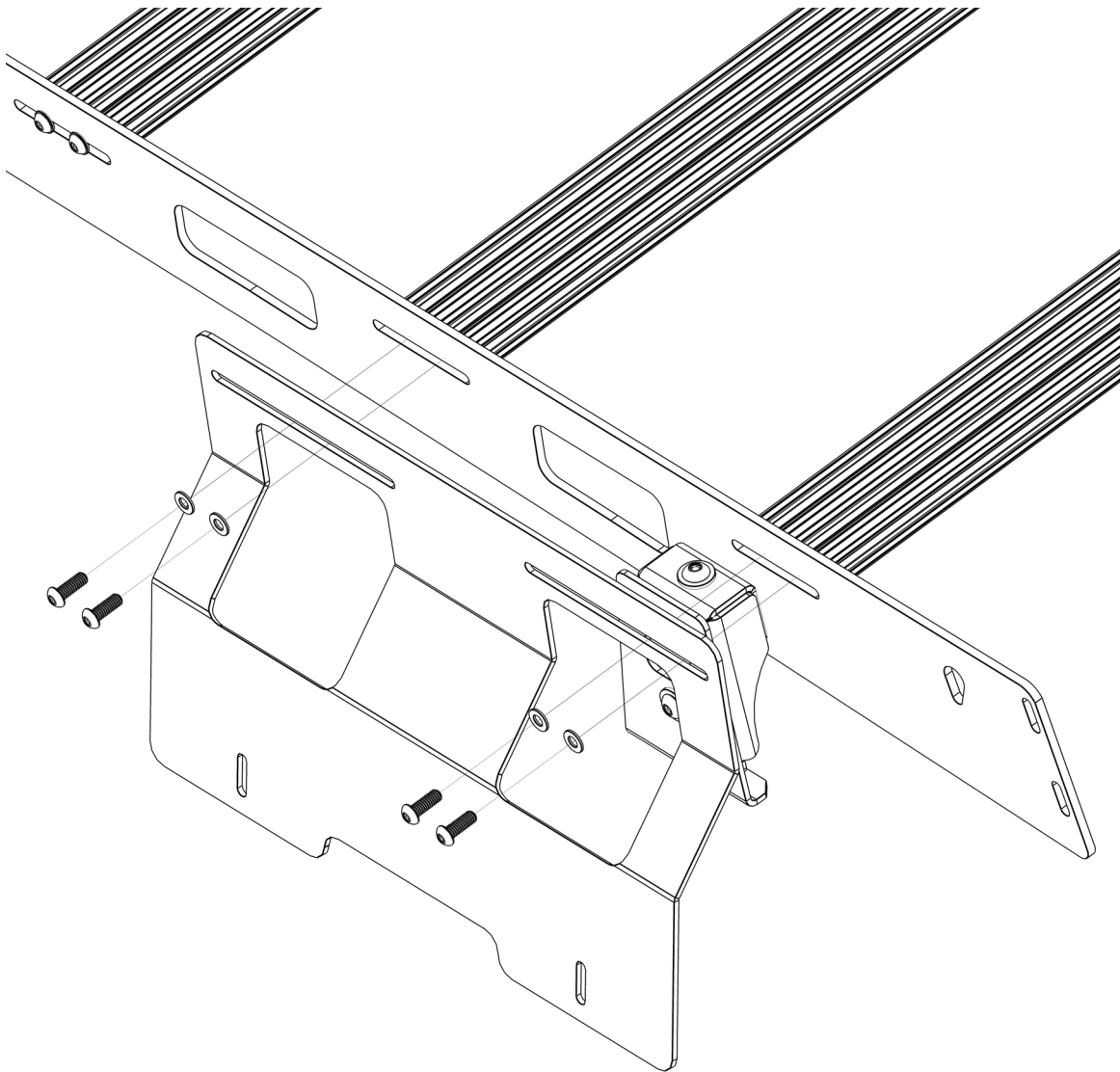

INSTALLATION

- 2** Next, mount the suction cup on the backside of the panel using the 1/4"-20 X 3/8" bolt. Make sure the button is pointing straight down.

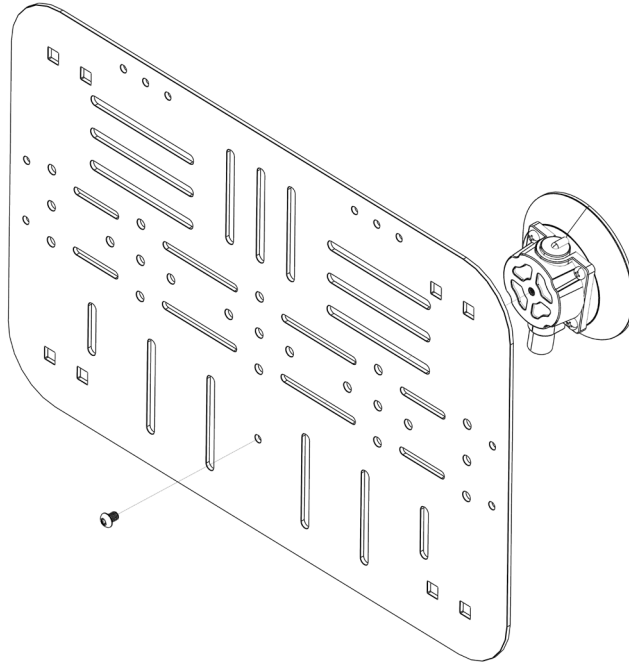

- 3** Next, loosely mount the panel to the outside of the mounting bracket using the 1/4"-20 X 3/4" bolts and 1/4"-20 serr. flange nuts.

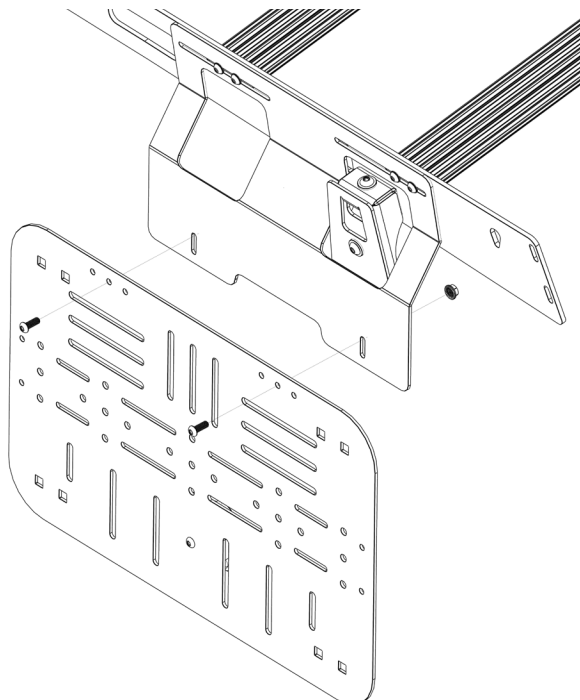

INSTALLATION

- 4 Finally, adjust the position of the mounting bracket until the panel is centered in the window. Then, push the bottom against the window and push the button on the bottom of the suction cup to stick it to the window. You can then tighten all the hardware.



XJ

SIDE ACCESSORY PANEL

INSTALL INSTRUCTIONS

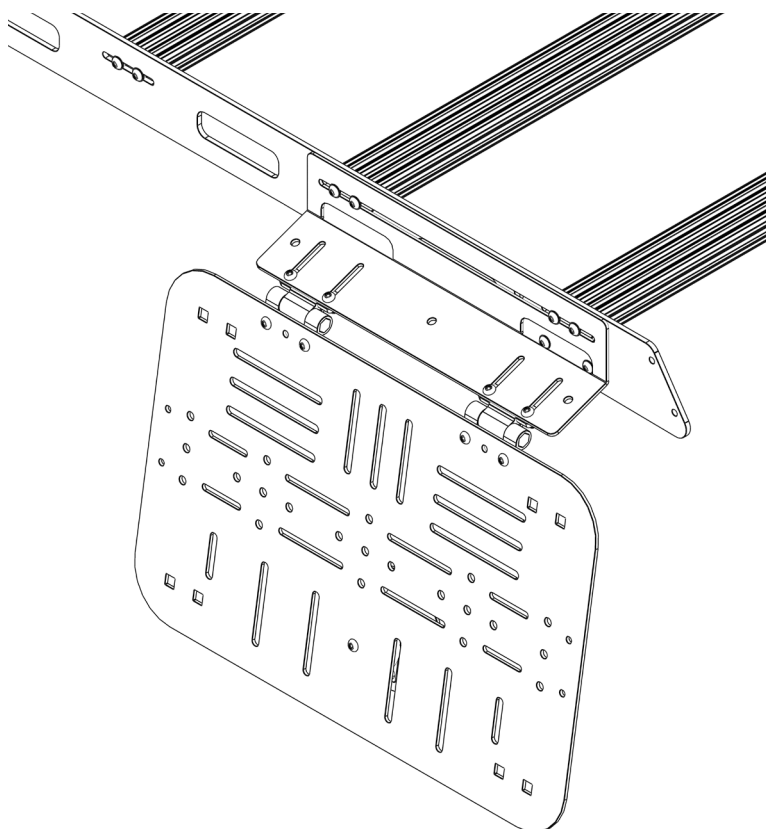

Please read the mounting instructions below carefully before attempting to install.

Be sure to check out the install video on the product page, if available.

Thank you for purchasing from JcROffroad! Checkout our website, www.jcroffroad.com for other great off-road products. Be sure to rate and review our product online. If you have any questions or are missing parts, please don't hesitate to call us at 269-353-1184!

INCLUDED HARDWARE

8x

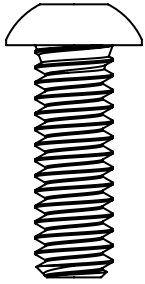

1/4"-20 X 3/4"
Button Head

1x

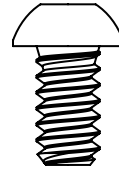

1/4"-20 X 3/8"
Button Head

8x

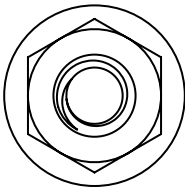

1/4"-20
Serr. Flange Nut

INCLUDED PARTS

1x

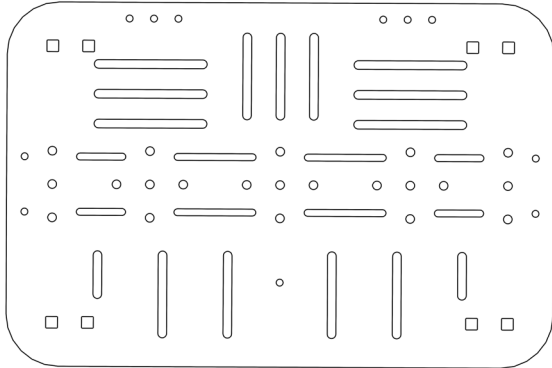

1x

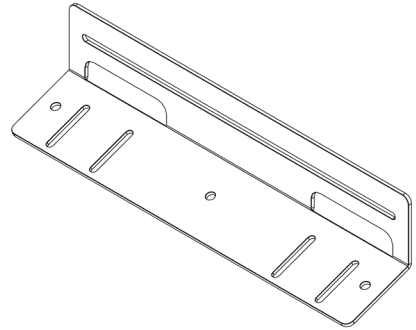

1x

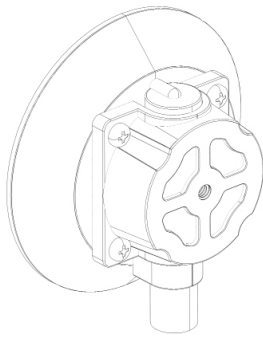

INSTALLATION

- 1 Start by loosely mounting the two hinges to the four slots in the bent bracket using the 1/4"-20 X 3/4" bolts and 1/4"-20 serr. flange nuts. It doesn't matter which side of the hinge as long as you put the flat side of the hinges on the bottom of the bracket.

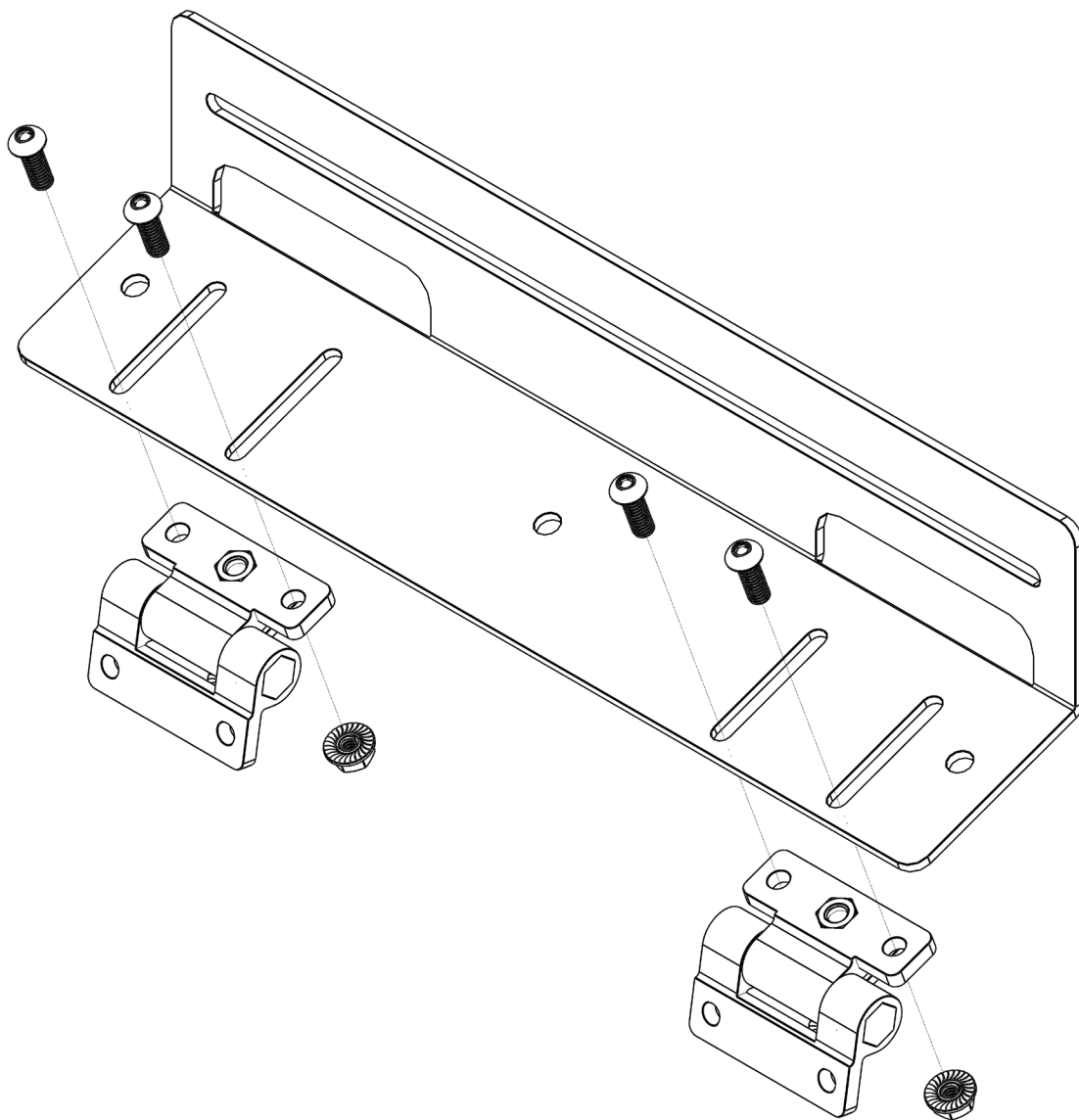

INSTALLATION

- 2 Next, loosely install the mounting bracket onto your roof rack. To do this, remove the bolts from the one end of the two rear most crossbars and use those bolts to mount the bracket to the side of the roof rack and back into the bars.

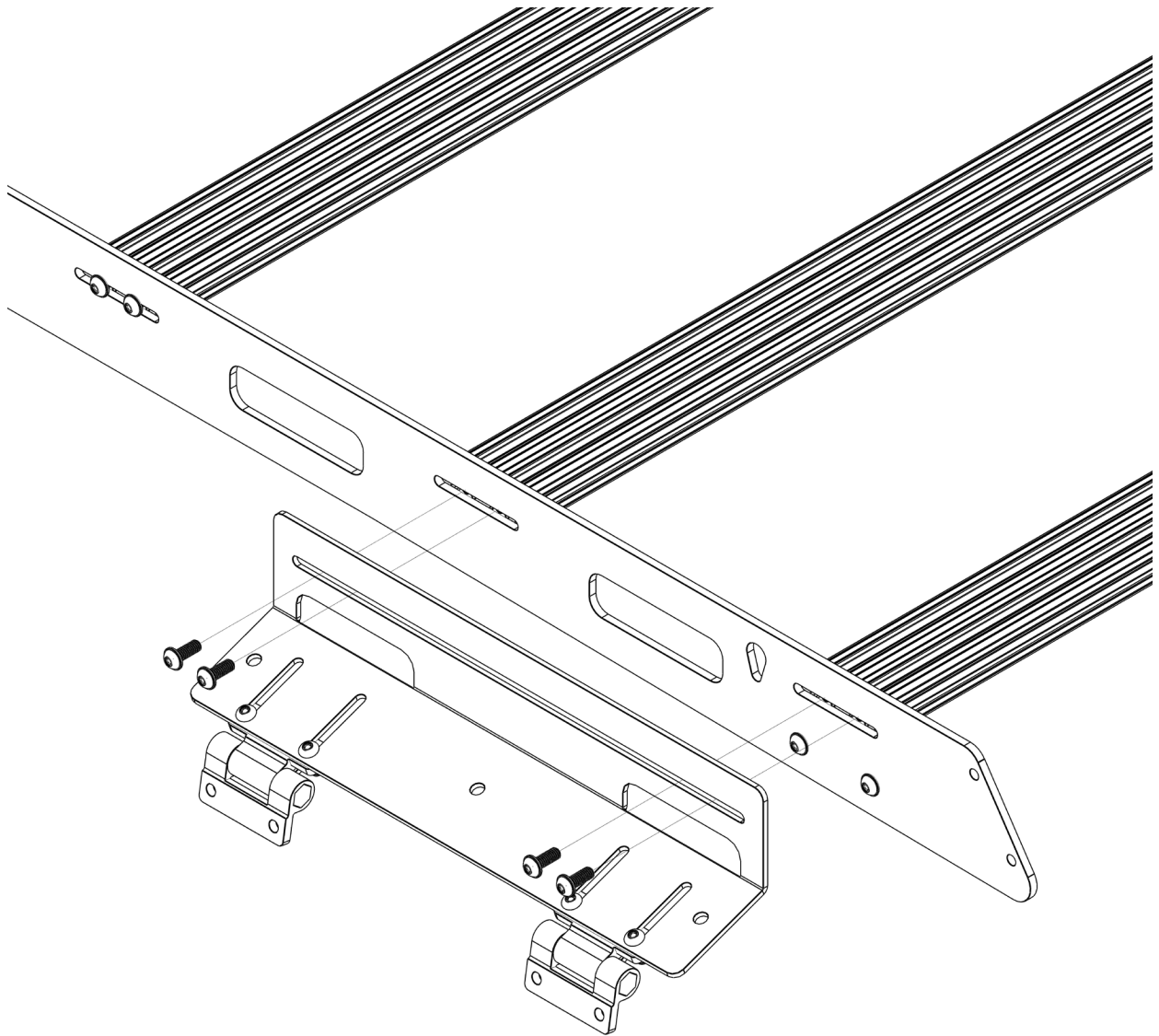

INSTALLATION

- 3** Next, mount the suction cup on the backside of the panel using the 1/4"-20 X 3/8" bolt. Make sure the button is pointing straight down.

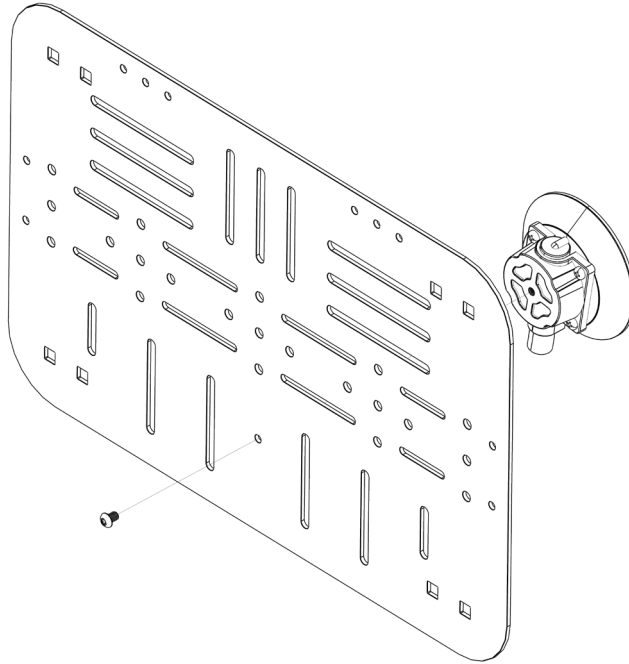

- 4** Next, loosely mount the panel to the other end of the hinges using the 1/4"-20 X 3/4" bolts and 1/4"-20 serr. flange nuts.

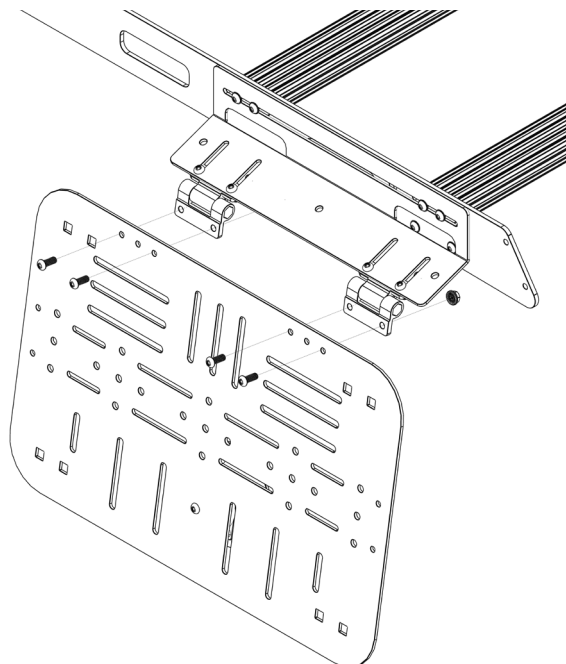

INSTALLATION

- 5** Finally, adjust the position of the mounting bracket until the panel is centered in the window. Then, push the bottom against the window until the suction cup is flat against it and push the button on the bottom of the suction cup to stick it to the window. You can then tighten all the hardware. If you would like to, you can also tighten the torsion screw on the hinges to lock them at the angle they are at.