

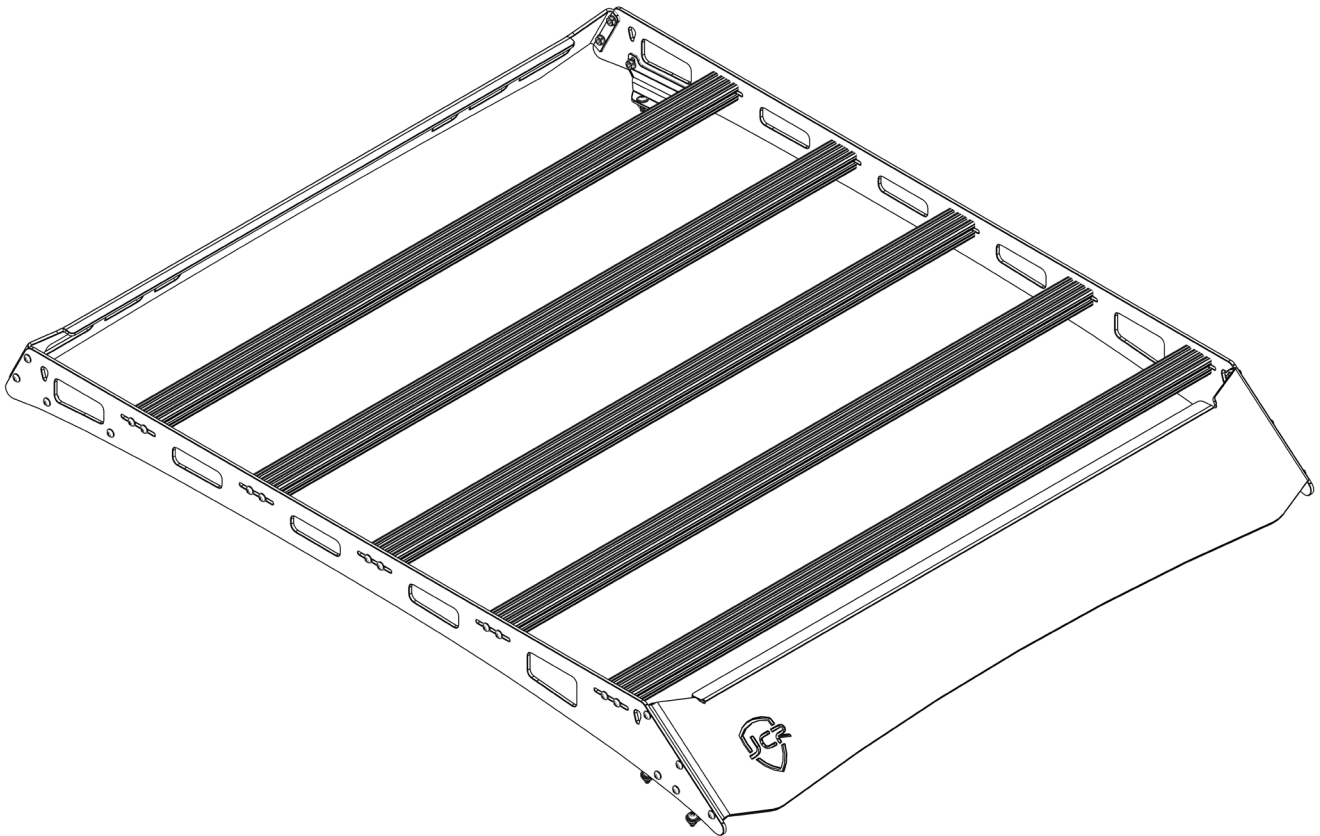

4TH GEN RANGER ROOF RACK

INSTALL INSTRUCTIONS



Please read the mounting instructions below carefully before attempting to install.

Check out the install video on the product page for factory rack disassembly.

Thank you for purchasing from JcROffroad! Checkout our website, www.jcroffroad.com for other great off-road products. Be sure to rate and review our product online. If you have any questions or are missing parts, please don't hesitate to call us at 269-353-1184!

INCLUDED HARDWARE

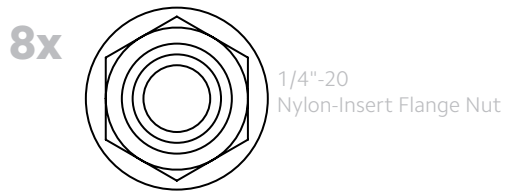
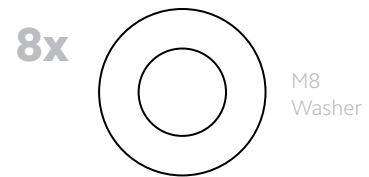
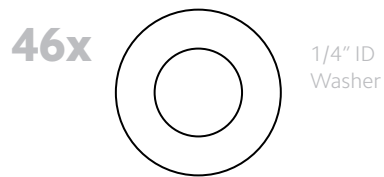
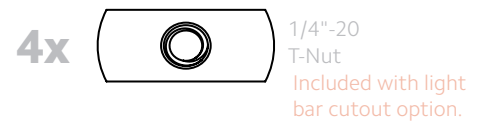
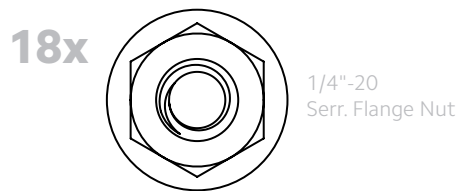
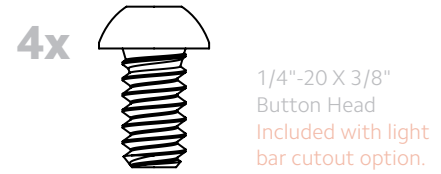

INCLUDED PARTS

2x

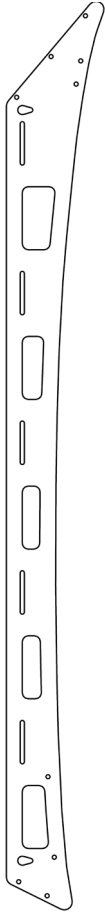

5x



1x



1x

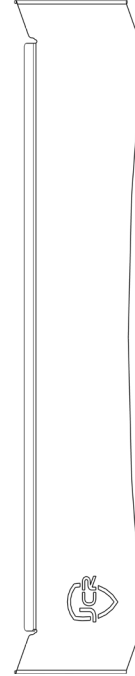

1x

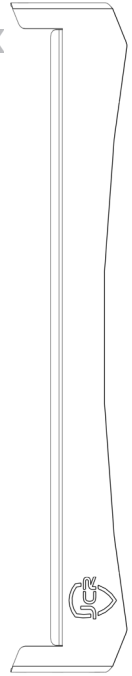

Or

1L/1R

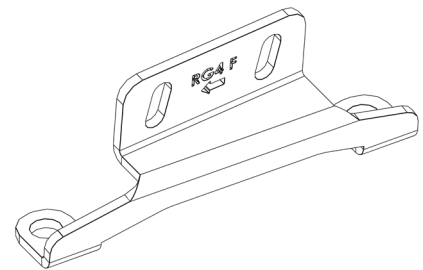

1L/1R

Included with light bar cutout option.

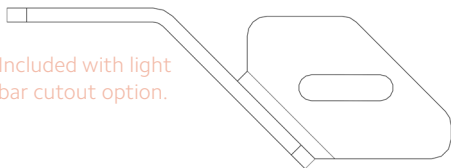

1L/1R

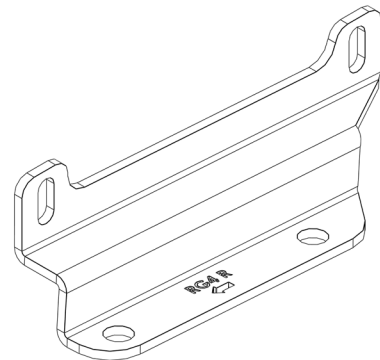

ASSEMBLY

- 1** Assemble the rack on the ground. Start by mounting the crossbars between the two side rails. For this, use the 1/4"-20 X 3/4" button head bolts and the 1/4" ID washers (2 per bar per side). Make sure the machined slot in the rail of the crossbar is facing up, so that you can easily add t-nuts to mount your gear.

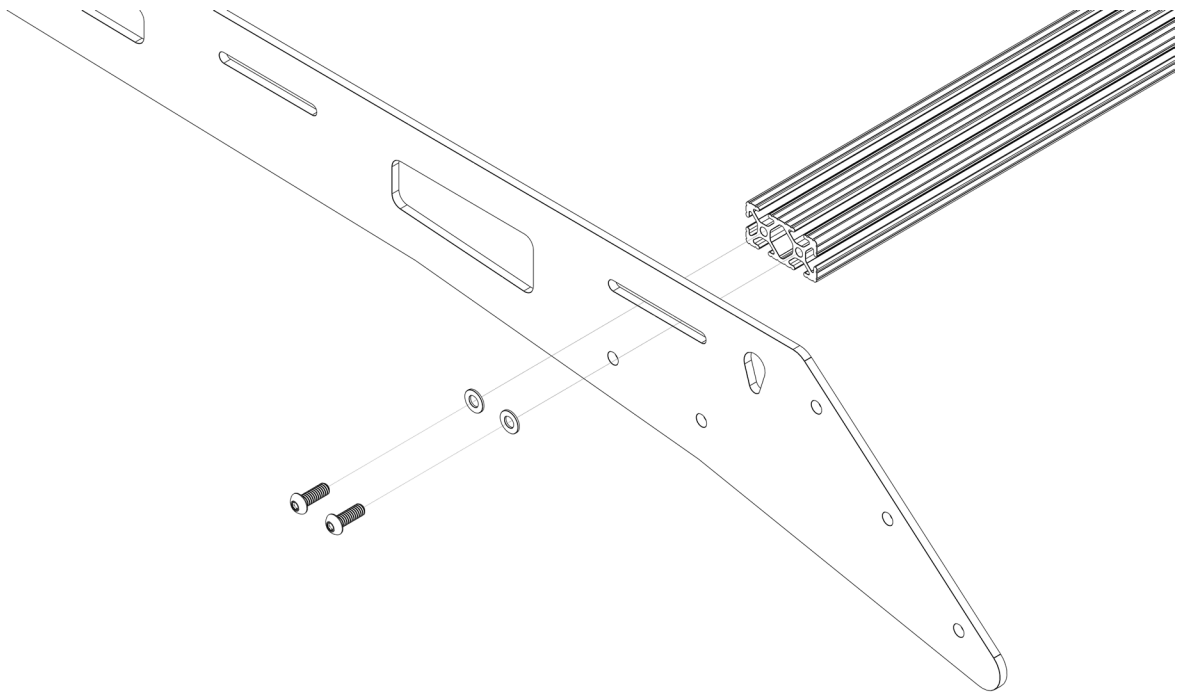

ASSEMBLY

- 2 Next, mount the strip of trim to the bottom edge of the front fairing. Start just to the outside of the peak of the bottom edge and continue until it reaches the equivalent point on the other side of the fairing. Cut off any extra. Then, cut the extra in half and mount the 2 pieces onto the bottom edge of the rear fairing wherever it contacts the roof of the vehicle.

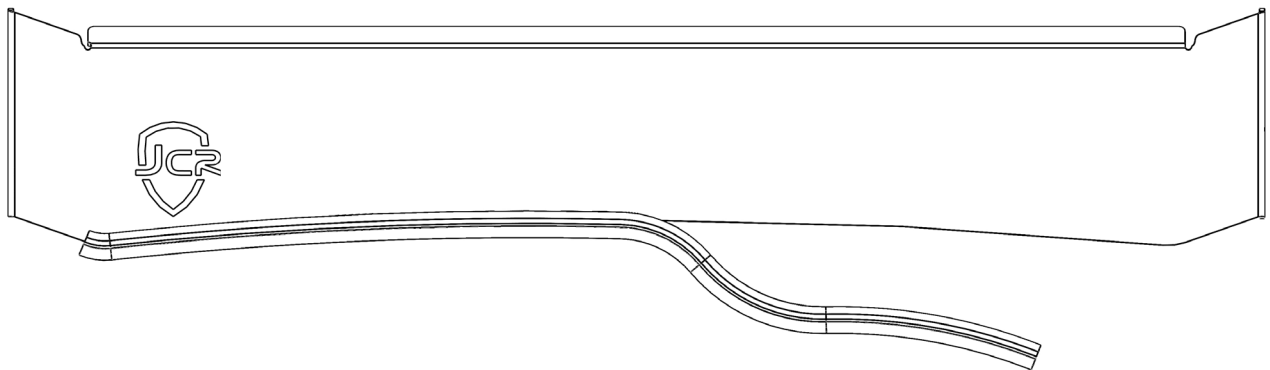

ASSEMBLY

- 3** Mount the front and rear fairings. To do this, use the 1/4"-20 X 3/4" button head bolts, 1/4" ID washers, and 1/4"-20 serrated flange nuts. The front fairing will need 3 of each per side and the rear fairing will need 2 of each per side. When mounting the fairings, adjust them all the way up and tighten to avoid contact with the roof when setting it in place.

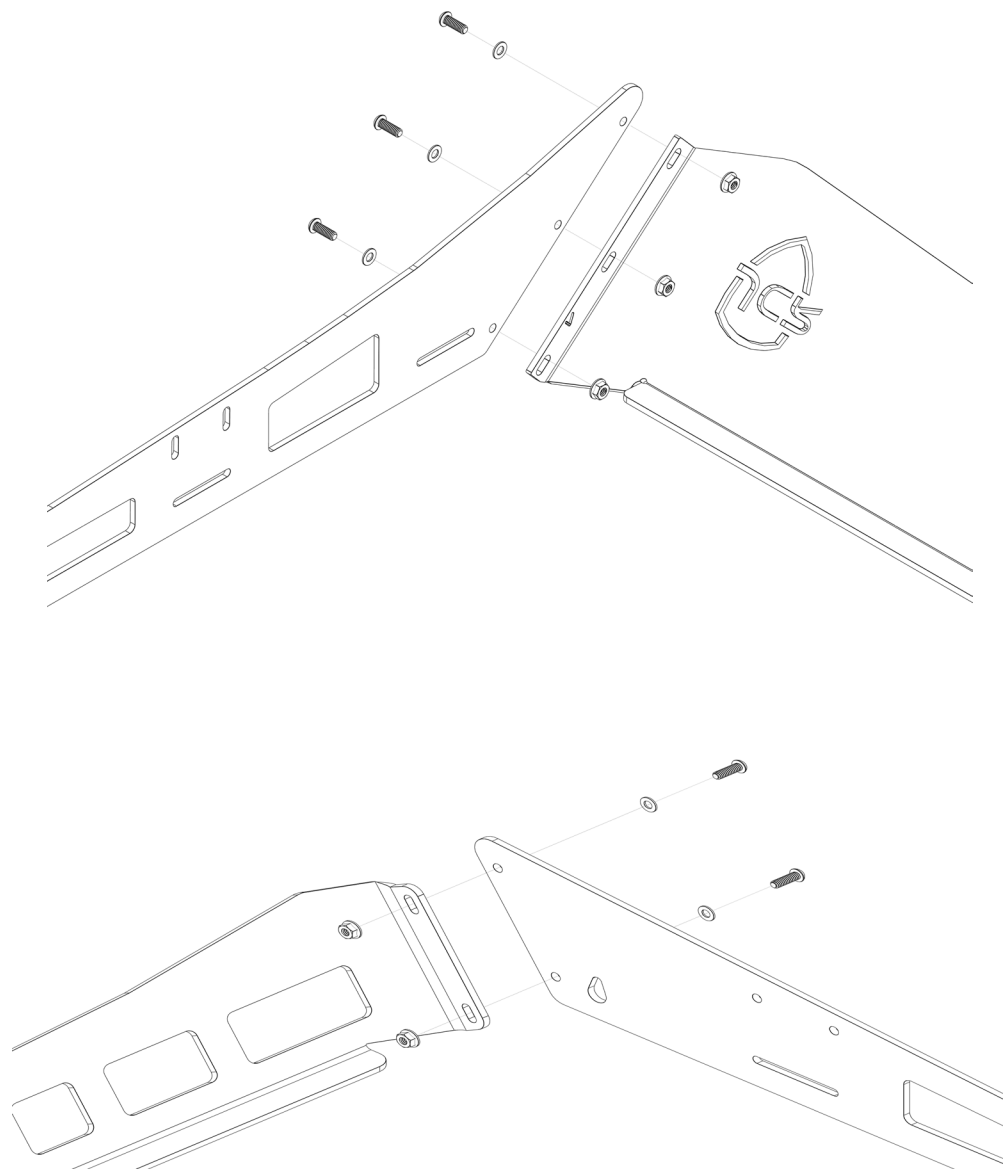

ASSEMBLY

- 4** Next, attach the mounts to the inside of the side rails using the 1/4"-20 X 3/4" button head bolts, 1/4" washers and 1/4" serrated flange nuts. The arrows should always be pointing towards the front of the vehicle. Push the mounts all the way down and tighten them for now so that the rack will be elevated off of the roof when testing the placement of the rack. Next you will need to drop part of the headliner. Check out the 4:40 of the installation video on the product page for instructions on that.

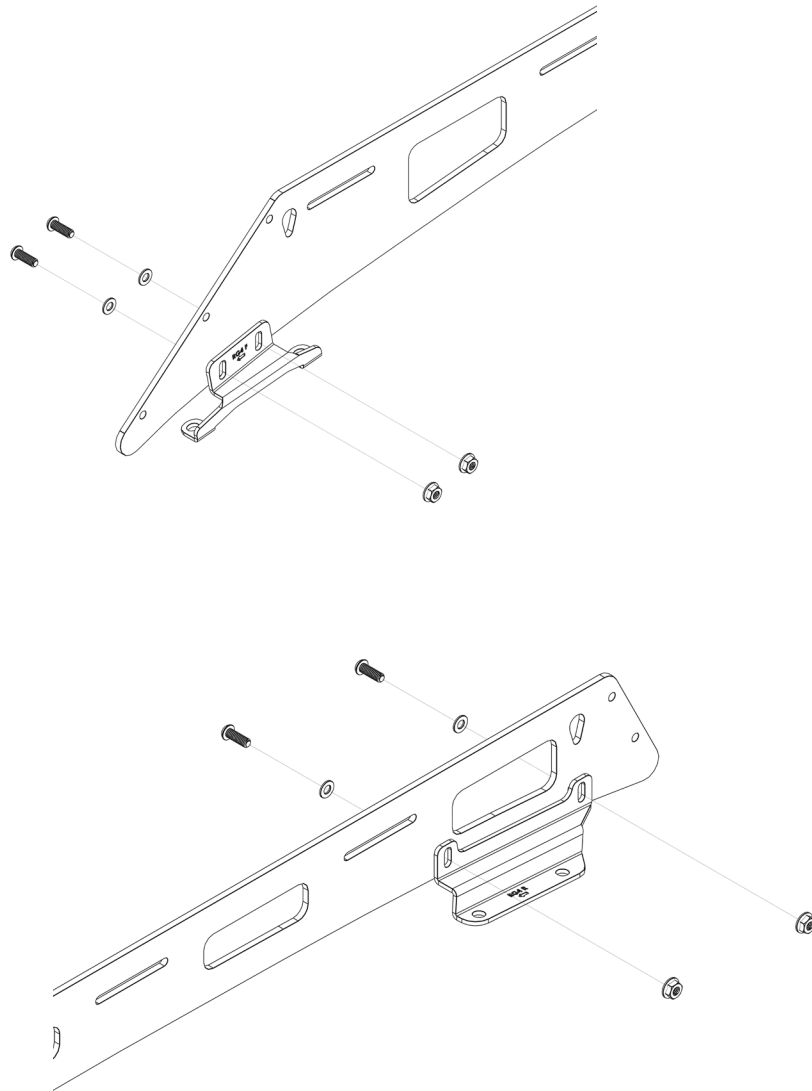

ASSEMBLY

- 5 Next, place the assembled rack up onto the roof and line the front hole in the front mount and rear hole in the rear mount in the factory holes in the roof of the vehicle. To make sure they stay lined up, it is best to put one of the 1/4" bolts through each of the holes. Once the rack is in place, mark the roof at each of the other holes so that you know where to drill. You can then pull the rack back off the roof and drill out those holes to 1/4". We highly recommend you use a drill stop set to roughly 1/4" to prevent you from drilling into the airbag. If you are worried about the saw stop damaging the paint on your vehicle, you can place a piece of masking tape over the area before drilling all the way through.
- 6 With the holes drilled, put a large bead of RTV sealant around each mounting hole and then set the rack back onto the roof. Then, apply another bead over the top of the holes in the mount, making sure to get some over the open hole so that the bolts will pass through it. Once that is done, secure the rack in place using 1/4"-20 X 3/4" bolts and M8 washers on the top with 1/4"-20 Nylon-insert nuts on the inside of the roof. To access the front mounts, it may be easiest to take out two of the bolts on each side of the front fairing so that you can rotate it out of the way.

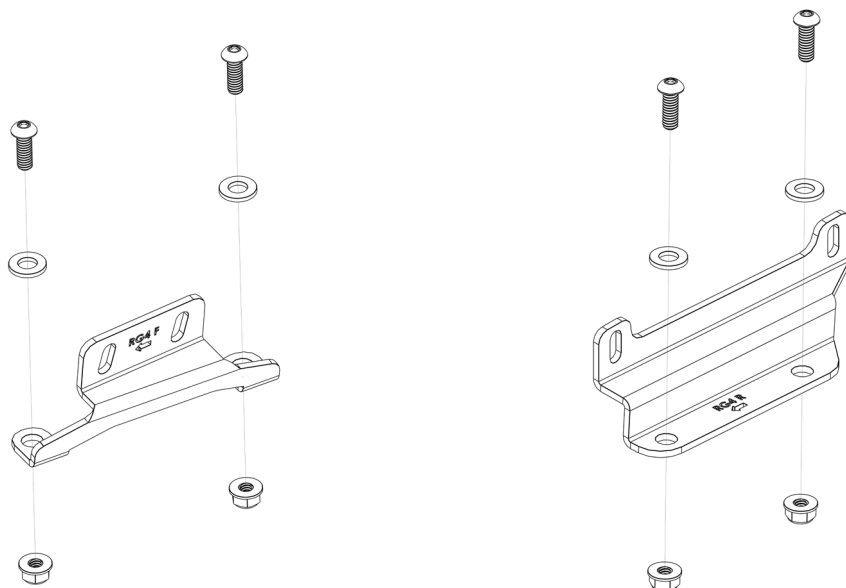

ASSEMBLY

- 6** With everything into place, make any adjustments that are necessary in order to get an even gap between the bottom edge of the rack and the roof, all the way down the length of the vehicle and then tighten everything into place.
- 7** Finally, push the front and rear fairings down tight to the roof of the vehicle and tighten everything fully into place. We recommend applying clear 3M paint protection film to the roof of the vehicle anywhere the edge trim/fairings make contact with the roof. This will protect the paint from dirt/debris over time.

40" LIGHT BAR ASSEMBLY

- 1** Slide 2 t-nuts into each of the channels on the top side of the front-most crossbar using the slots. Then, place each light bar mount over one pair of t-nuts and loosely bolt it in place using the 1/4"-20 X 3/8" button heads.

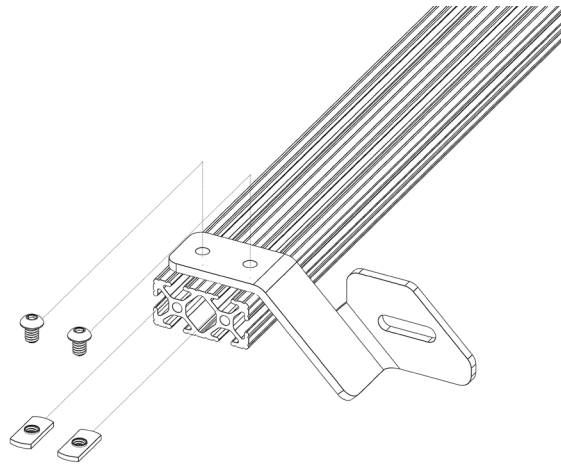

- 2** Next, place your light bar between the mounts and mount it in the slots using the hardware provided with the light bar. After that is firmly in position, make any adjustments to the positioning necessary to center the light bar on the rack. Depending on the rack and light bar, you may need to adjust the position of the cross bar in its slot as well.

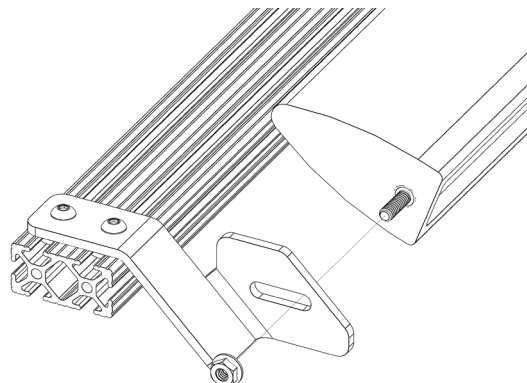

DIMENSIONS

