

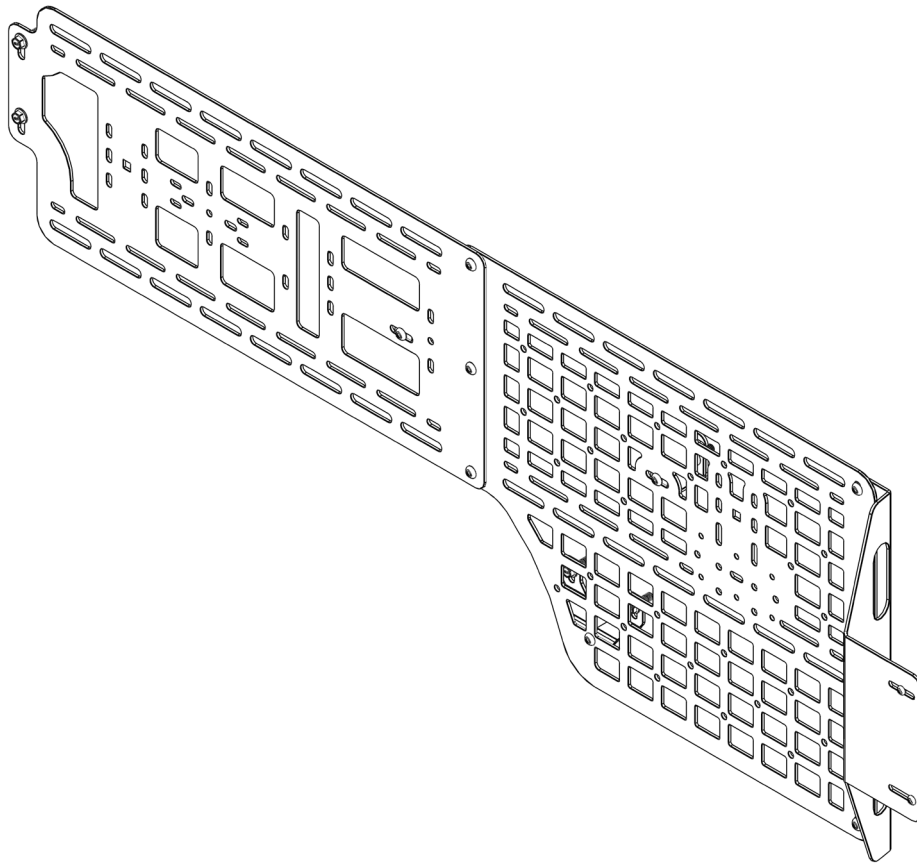

4TH GEN RANGER

REAR MOLLE PANEL

INSTALL INSTRUCTIONS



Please read the mounting instructions below carefully before attempting to install.

Be sure to check out the install video on the product page, if available.

Thank you for purchasing from JcROffroad! Checkout our website, www.jcroffroad.com for other great off-road products. Be sure to rate and review our product online. If you have any questions or are missing parts, please don't hesitate to call us at 269-353-1184!

INCLUDED HARDWARE

8x

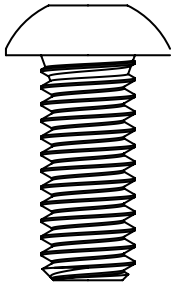

5/16"-18 X 5/8"
Button Head

8x

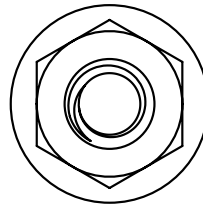

5/16"-18
Serr. Flange Nut

4x

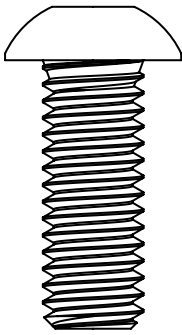

3/8"-16 X 1"
Button Head

4x

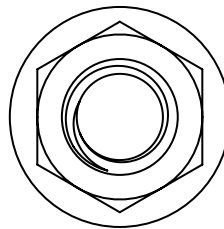

3/8"-16
Serr. Flange Nut

4x

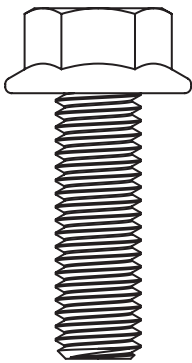

25mm M8
Flanged Hex Head

2x

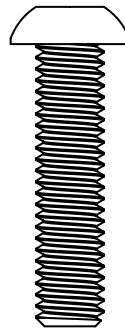

25mm M6
Button Head

INCLUDED PARTS

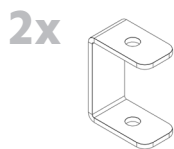
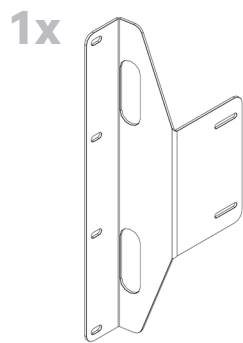
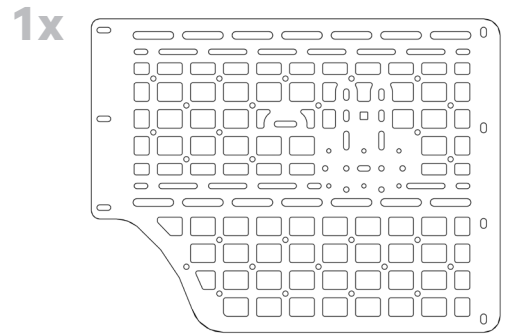
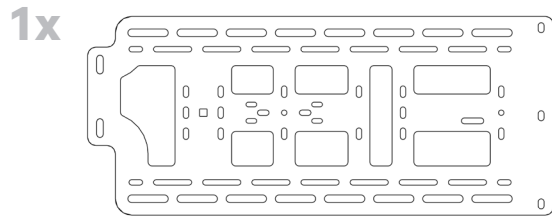

ASSEMBLY

- 1 Start by loosely attaching the two panels as well as the rear bracket using the 5/16"-18 X 5/8" button heads and 5/16"-18 serr. flange nuts. The front panel should sit towards the inside when installed, and the rear panel should sit between the front panel and the bracket. The larger cutout in the front panel and the curved cutout in the rear panel both go on the bottom.

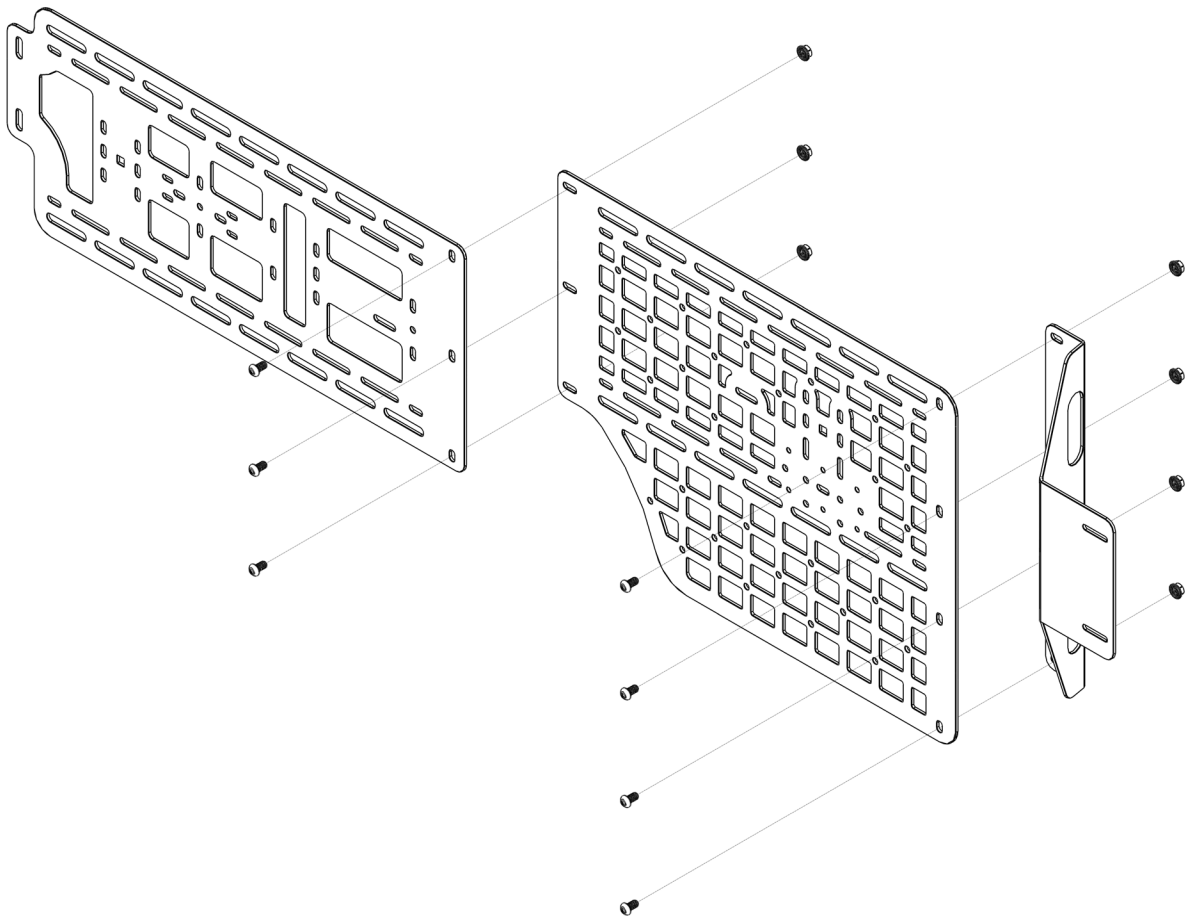

ASSEMBLY

- 2 Once the panels are assembled, install the bottom mount into the factory threaded holes using the M8 bolts. The horizontal slot should be towards the ground. If you have a spray in bed-liner, you may need to tap the holes using a M8 X 1.25mm tap.

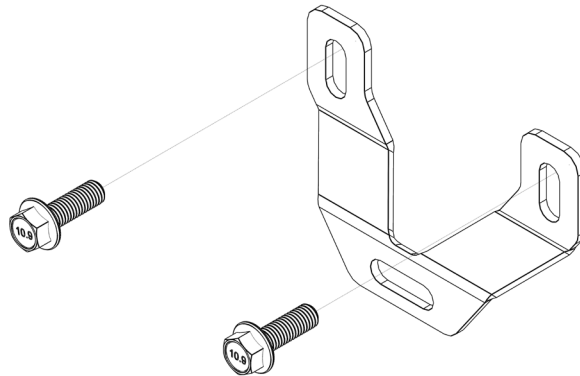

- 3 Next, loosely assemble the upper mounts as shown below. Then, remove the plastic plugs from the bedside and insert the flat washer into the exposed holes. Once the flat washer is sitting in the hole vertically, lightly pull out on the rectangular bracket and tighten it into place.

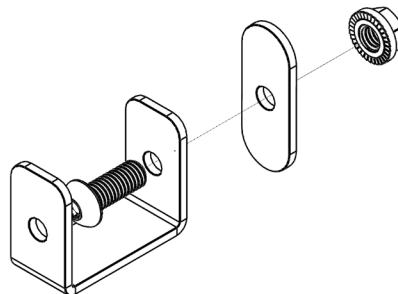

ASSEMBLY

- 4** Finally, mount the panels to the bedside and mounts. The front and back mount directly to the bedside using M8 bolts and M6 bolts respectively. If you have a spray in bed-liner, you may need to tap these holes as well. The mounts attach to the panels using 5/16"-18 X 5/8" button heads and 5/16"-18 serr. flange nuts.

