



# TABLE OF CONTENTS

6TH GEN BRONCO 4 DOOR FULL RACK.....	2
6TH GEN BRONCO 2 DOOR FULL RACK.....	14
40" LIGHT BAR.....	27



# 6TH GEN BRONCO 4 DOOR HARD TOP FULL RACK

## INSTALL INSTRUCTIONS

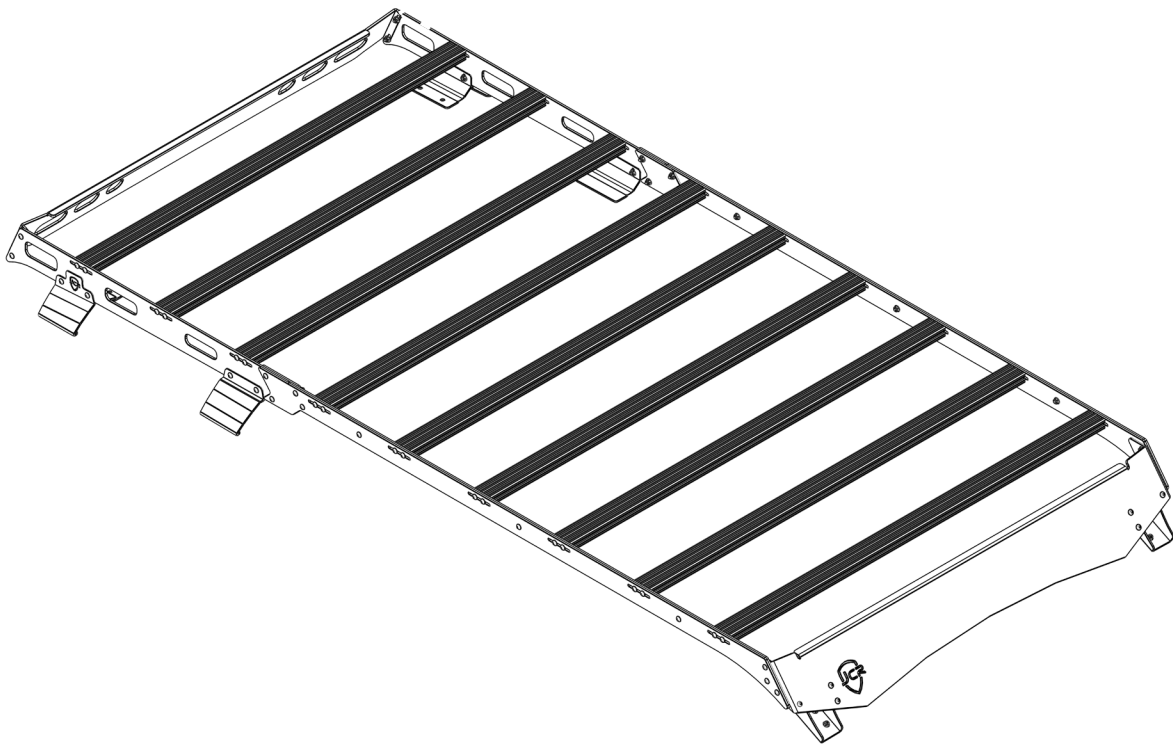

**Please read the mounting instructions below carefully before attempting to install.**

**Check out the install video on the product page for factory rack disassembly.**

Thank you for purchasing from JcROffroad! Checkout our website, [www.jcroffroad.com](http://www.jcroffroad.com) for other great off-road products. Be sure to rate and review our product online. If you have any questions or are missing parts, please don't hesitate to call us at 269-353-1184!

# INCLUDED HARDWARE

60x

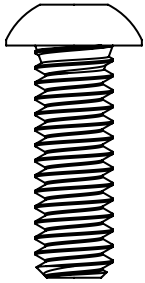

1/4"-20 X 3/4"  
Button Head (Silver)

4x

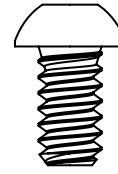

1/4"-20 X 3/8"  
Button Head  
Included with light  
bar cutout option.

6x

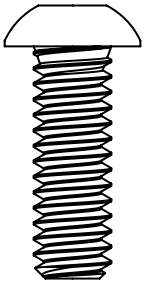

1/4"-20 X 3/4"  
Button Head (Black)

4x



1/4"-20  
T-Nut  
Included with light  
bar cutout option.

8x

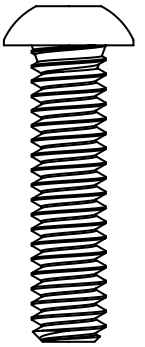

1/4"-20 X 1"  
Button Head (Black)

38x

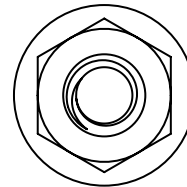

1/4"-20  
Serr. Flange Nut

74x

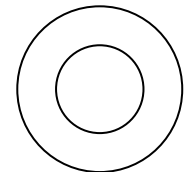

1/4" ID  
Washer

# INCLUDED PARTS

2x



2x

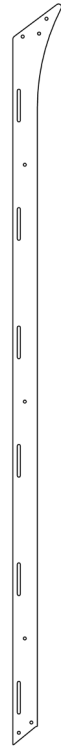

2x

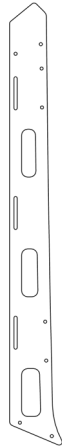

9x



1x



1x



1x

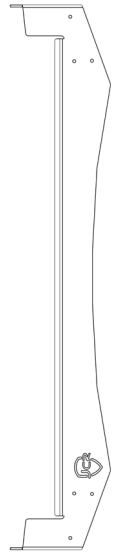

Or

2x



1L/1R

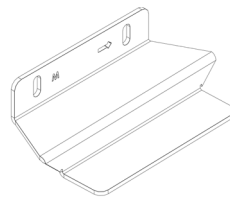

1L/1R

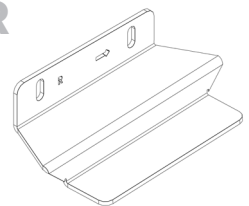

1L/1R

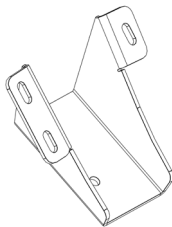

1L/1R

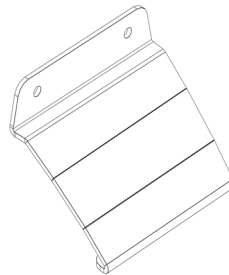

1L/1R

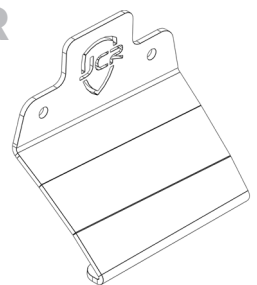

1L/1R



Included with light bar cutout option.

# ASSEMBLY

- 1 Start by mounting three crossbars between the two shorter side rails. For this, use the 1/4"-20 X 3/4" button head bolts and the 1/4" ID washers (2 per bar per side). Make sure the machined slot in the rail of the crossbar is facing up so you can easily add t-nuts to mount your gear.

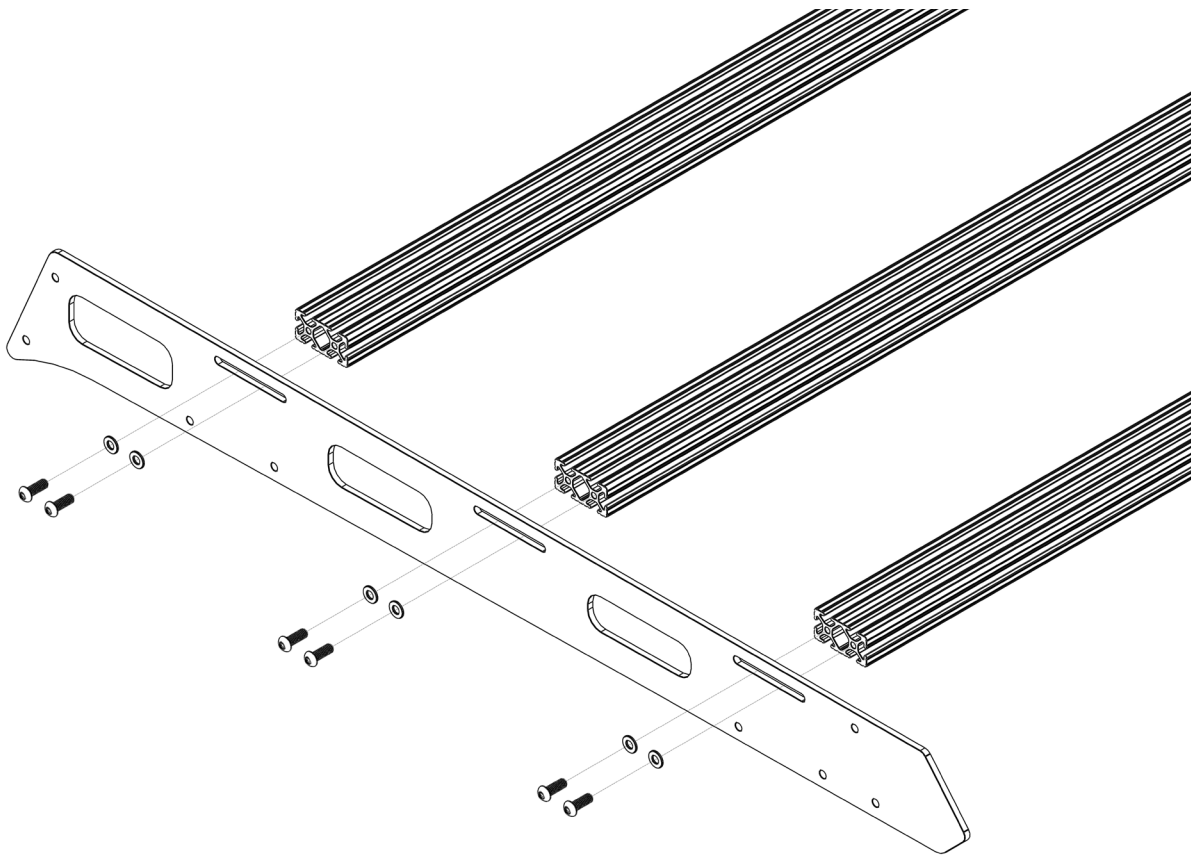

# ASSEMBLY

- 2** Next, find the inner mounts labeled M and R. The inner mounts are the ones with the sharper angles. Apply one of the provided rubber sheets to the bottom of each of them, making sure that the rubber hugs the bracket tightly across the entire bottom. For visual aid on this step, check out 1:55 in the instruction video at the bottom of the rack's product page.
- 3** Once the rubber is on each mount, loosely attach them to the inside of the side rails using the 1/4"-20 X 3/4" button head bolts, 1/4" ID washers and 1/4"-20 serr. flange nuts. The mounts labeled R go towards the rear (the flatter side) and the mounts labeled M go towards the front. Each mount should have an arrow pointing towards the front. With the mounts in place, set the rack on the hard top with each mount sitting flat in the indentations on the hard top.

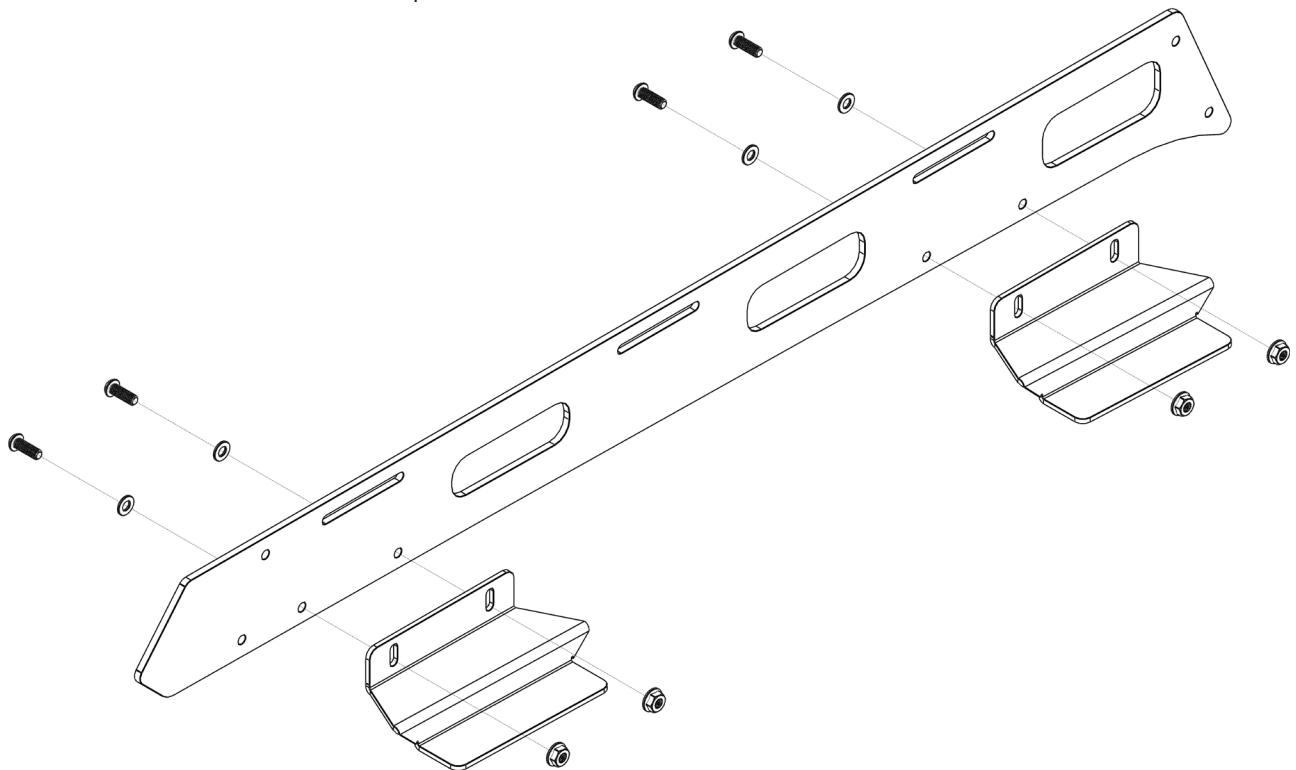

# ASSEMBLY

- 4 Next, find the outer R and M mounts and apply the remaining rubber sheets the bottom of each, similar to the inner mounts. Be sure to cover the top of the hook portion as well. For visual aid on this step, check out 5:20 in the instruction video at the bottom of the rack's product page.
- 5 Once the rubber is in place, remove the hardware holding the inner mounts in place and loosely install the outer mounts using that hardware. They mount to the outside of the side rails through the same holes as the inner mounts and the bottom hook flange slides into the cutouts in the side of the hardtop above the windows. It is easiest to do this one at a time with a rag under the corner of the rack that isn't being supported by a mount. That way there is no risk of the rack scratching the roof surface. The mounts labeled R go together and the mounts labeled M go together. The arrows should be pointing towards the front. Once everything is loosely in place, go back and tighten all the hardware while making sure that the inner mounts are pushed down tight to the surface of the roof.

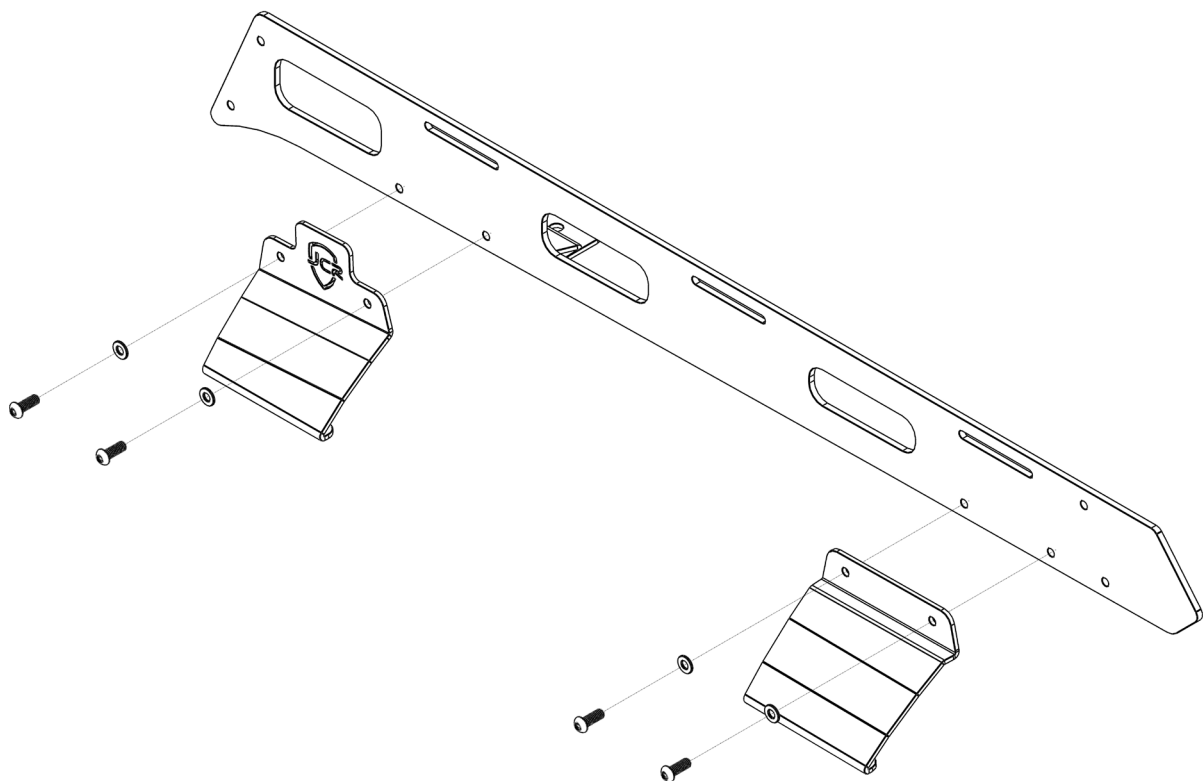

# ASSEMBLY

- 6** With the rear portion of the rack installed, you can begin to work on the front portion. Start by removing the accessory ready caps above the front windshield and then remove the plastic piece underneath using a 10mm socket. With those out of the way, you can place the front mounts into place in each of them. The arrows should point forward, and the single holed flange should be on the outside. Take care not to over tighten the nut when reinstalling.
- 7** Once the front mounts are in place, you will need to make some modifications to the covers and plastic pieces before you reinstall them. For the black plastic pieces, you will need to cut a few tabs and a ridge from the bottom of each so they can sit flat against the mounts. The covers will also need to be cut to fit over the mounts. The easiest way to do this is to make a straight cut from the front to the back just to the inside of the outside edge. If you want a little bit of a cleaner look, you can take the time to only cut where it contacts the mount. Some trimming of the inside edge may be required as well.
- 8** With the modifications made, place the black plastic pieces into place on top of the mounts and fasten them both in place using the factory nuts. Then simply pop the covers back into place.

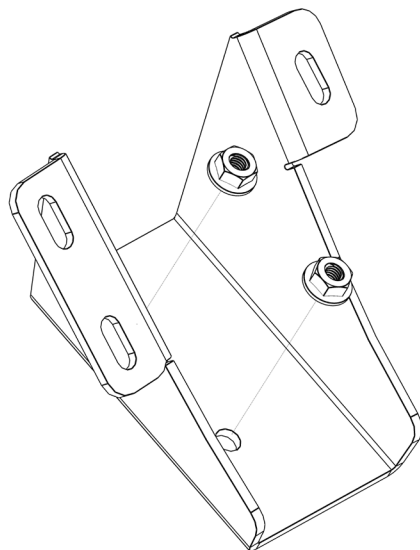



# ASSEMBLY

- 9** Next, mount the strip of trim to the bottom edge of the front fairing. Start just to the outside of the peak of the bottom edge and continue until it reaches the equivalent point on the other side of the fairing. Cut off any extra. Then, do the same thing for the rear fairing using the other piece of trim.

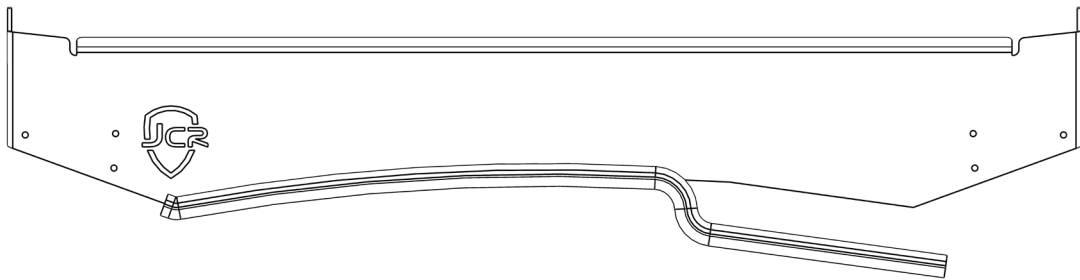

- 10** Next, loosely assemble the side rails as shown below. The longer side rail goes on the outside and the small bracket goes on the inside. The two side rails get bolted together using the black 1/4"-20 X 3/4" button head bolts, 1/4" ID washers and 1/4"-20 serr. flange nuts. The bracket bolts into place using a 1/4"-20 X 1" button head bolt, 1/4" ID washer and 1/4"-20 serr. flange nut in each of the front two holes.

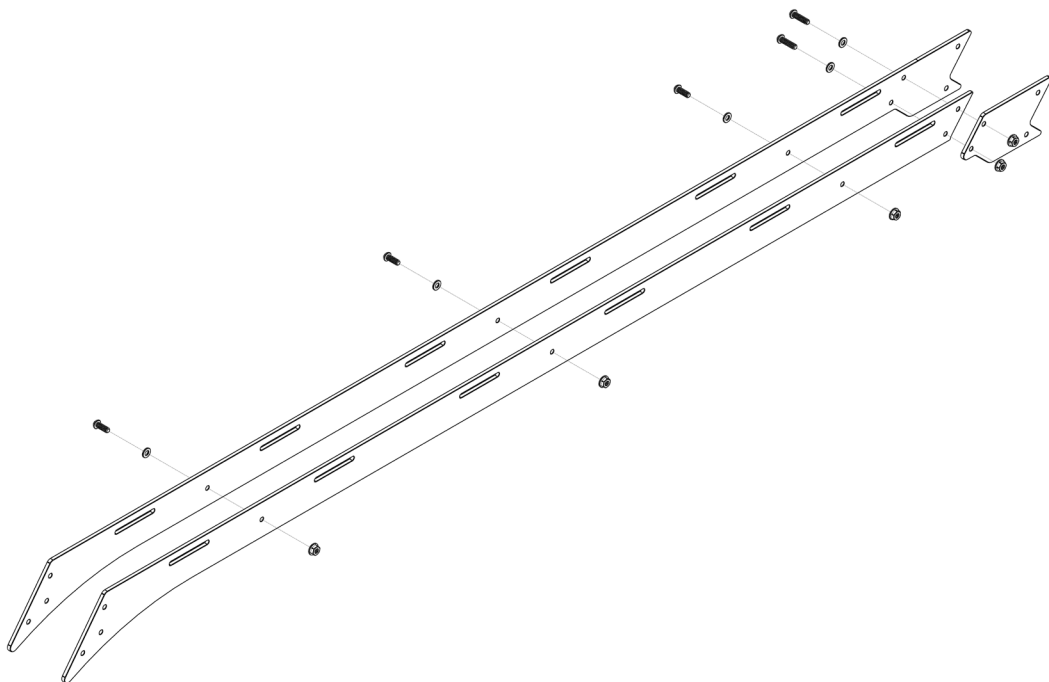

# ASSEMBLY

- 11** Once the components are assembled, loosely mount the front fairing to the front mounts using the 1/4"-20 X 3/4" button head bolts, 1/4" ID washers and 1/4"-20 serr. flange nuts. We recommend applying clear 3M paint protection film to the roof of the vehicle anywhere the edge trim/fairings make contact with the roof. This will protect the paint from dirt/debris over time.

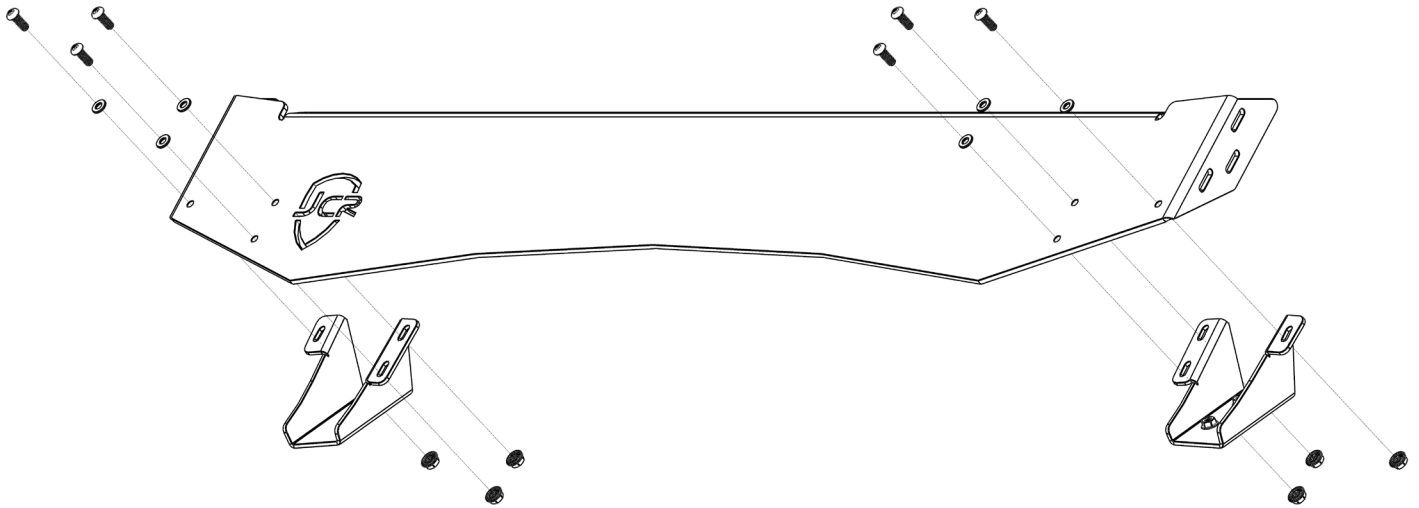

# ASSEMBLY

- 12** With the front fairing in place, loosely mount the side rails into place using the silver 1/4"-20 X 3/4" button head bolts into the fairing, black 1/4"-20 X 1" button head bolts into the bracket, 1/4" ID washers and 1/4"-20 serr. flange nuts. The front of the rails bolt onto the outside edges of the front fairings while the rear slides over and sandwiches the front edge of the rear side rails. Once everything is loosely assembled, go back and tighten all the hardware in to place. Make sure the front fairing sits tight to the roof.

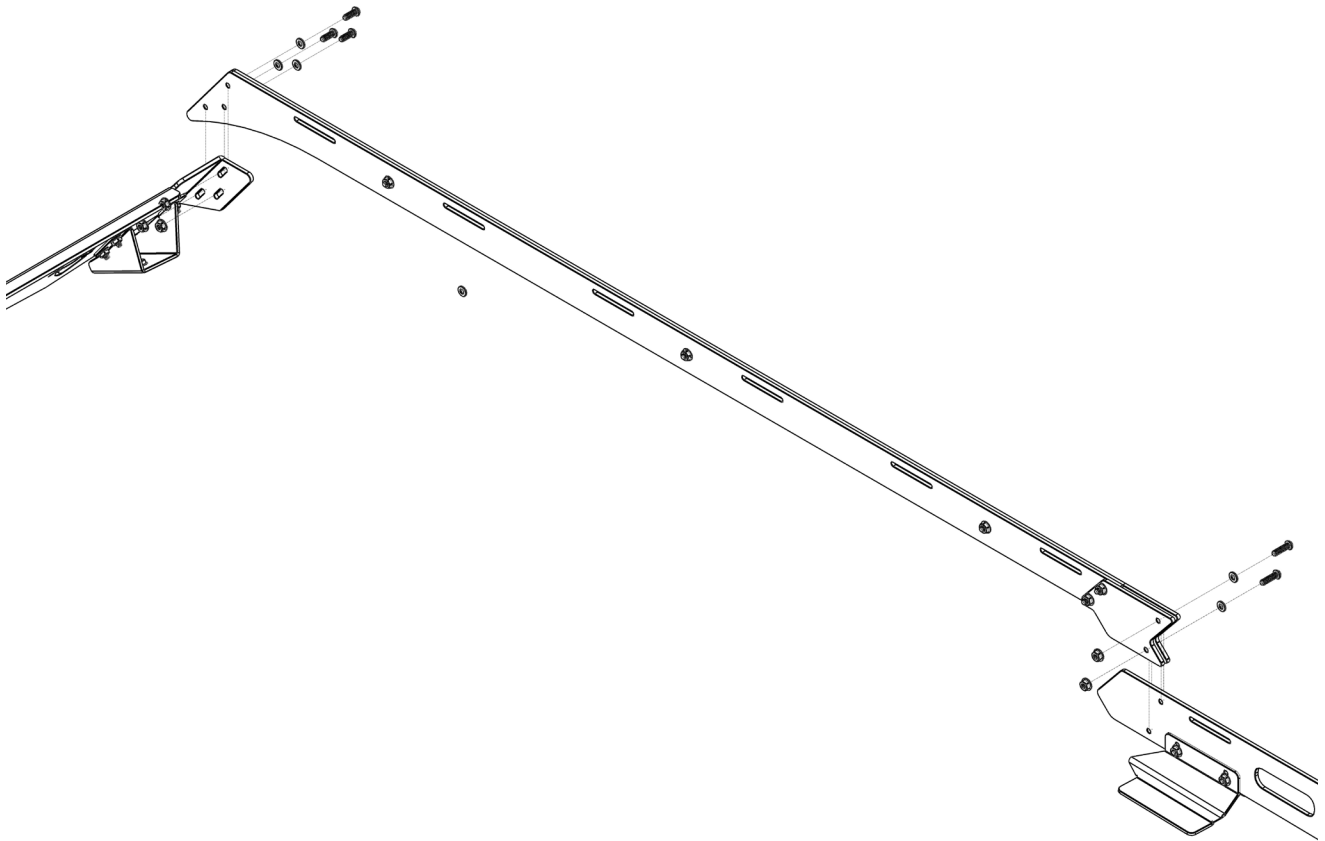

# ASSEMBLY

- 13** After the side rails are in place, you can install the remaining cross bars between them using the 1/4"-20 X 3/4" button head bolts and 1/4" ID washers. Make sure the machined slot in the rail of the crossbar is facing up so you can easily add t-nuts to mount your gear.

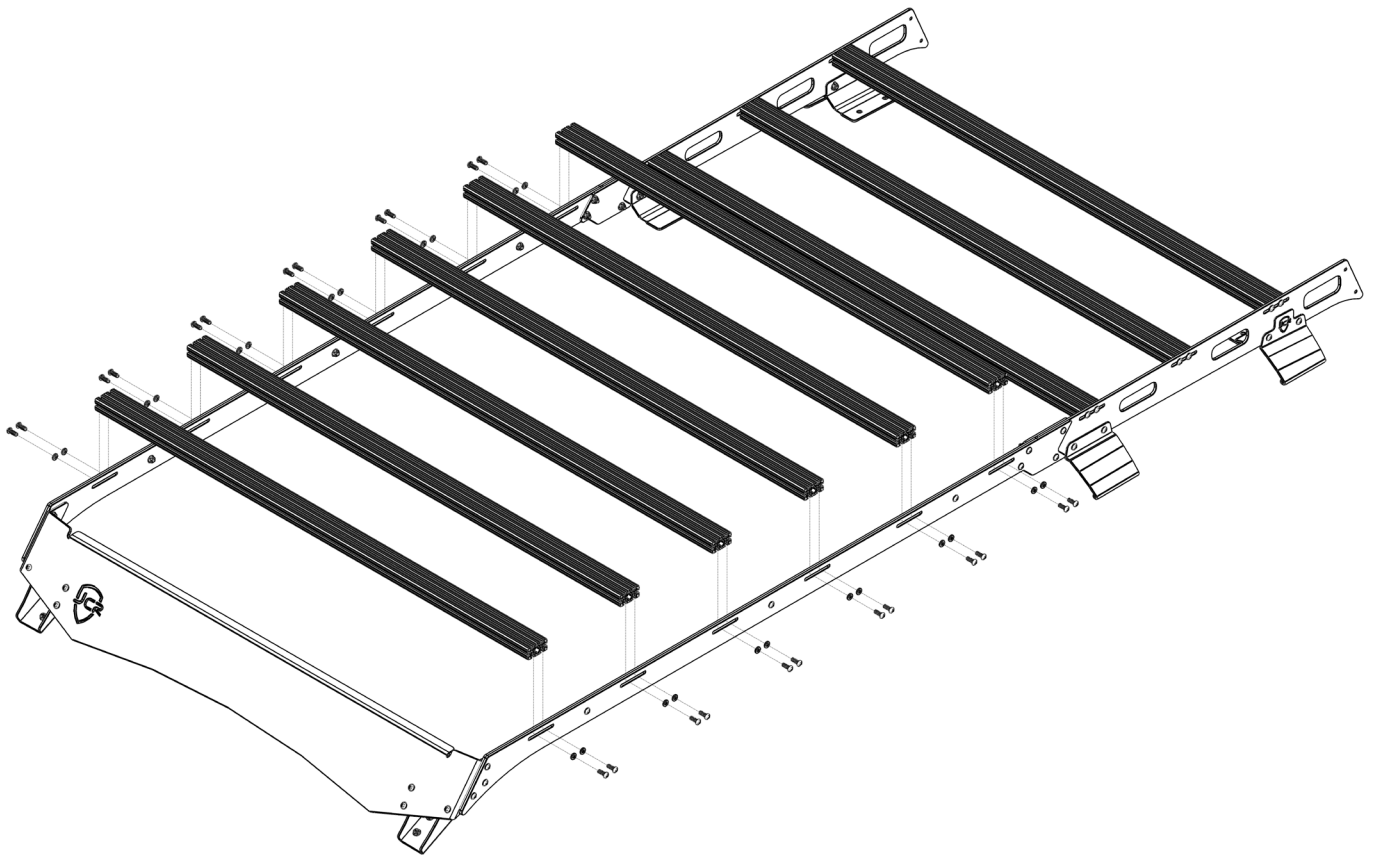

- 14** Finally, install the rear fairing between the rear side rails using the 1/4"-20 X 3/4" button head bolts, 1/4" ID washers and 1/4"-20 serr. flange nuts. Once it is loosely in place, push it tight to the roof and tighten it into place.

# DIMENSIONS

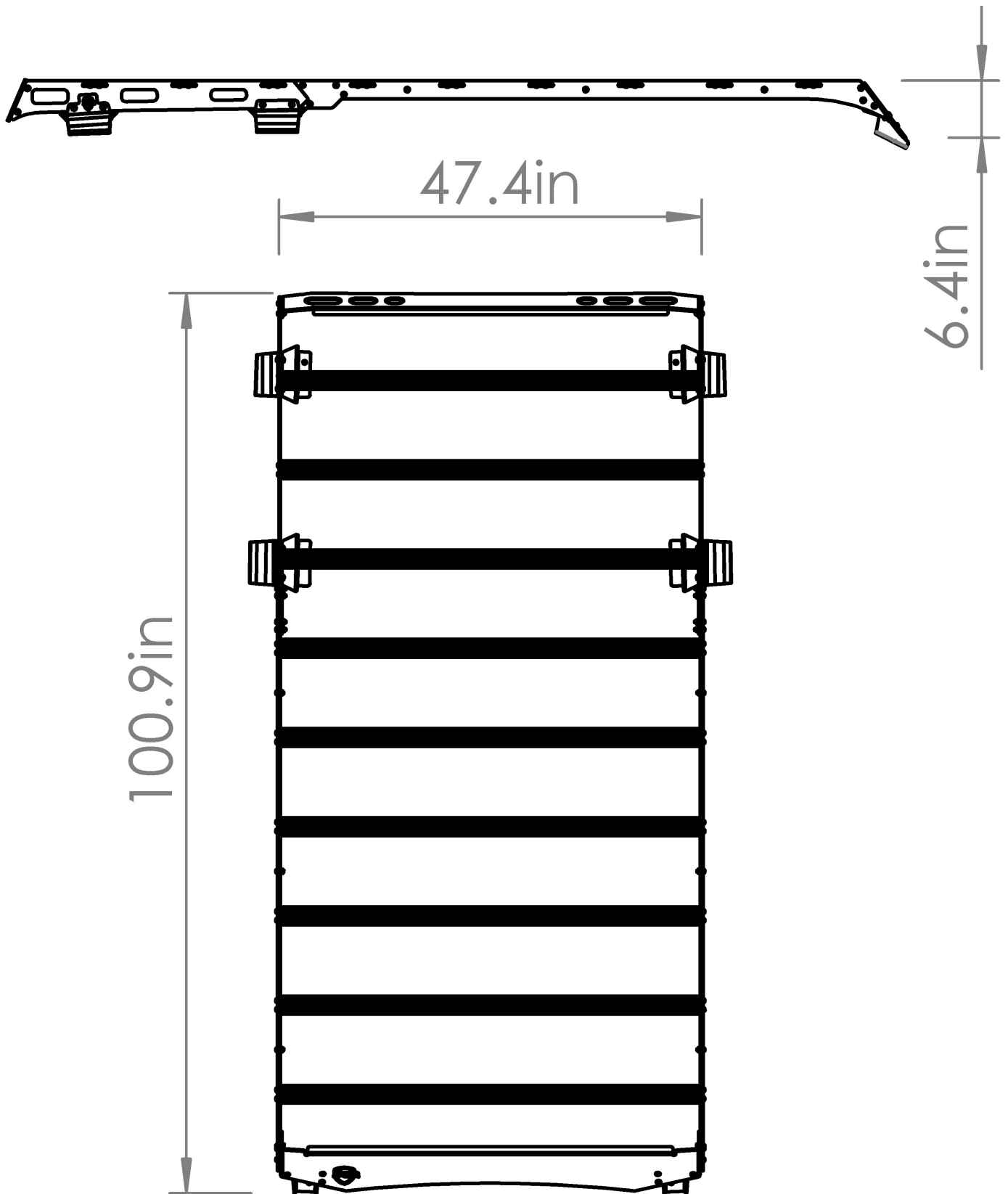



# 6TH GEN BRONCO 2 DOOR HARD TOP FULL RACK

## INSTALL INSTRUCTIONS

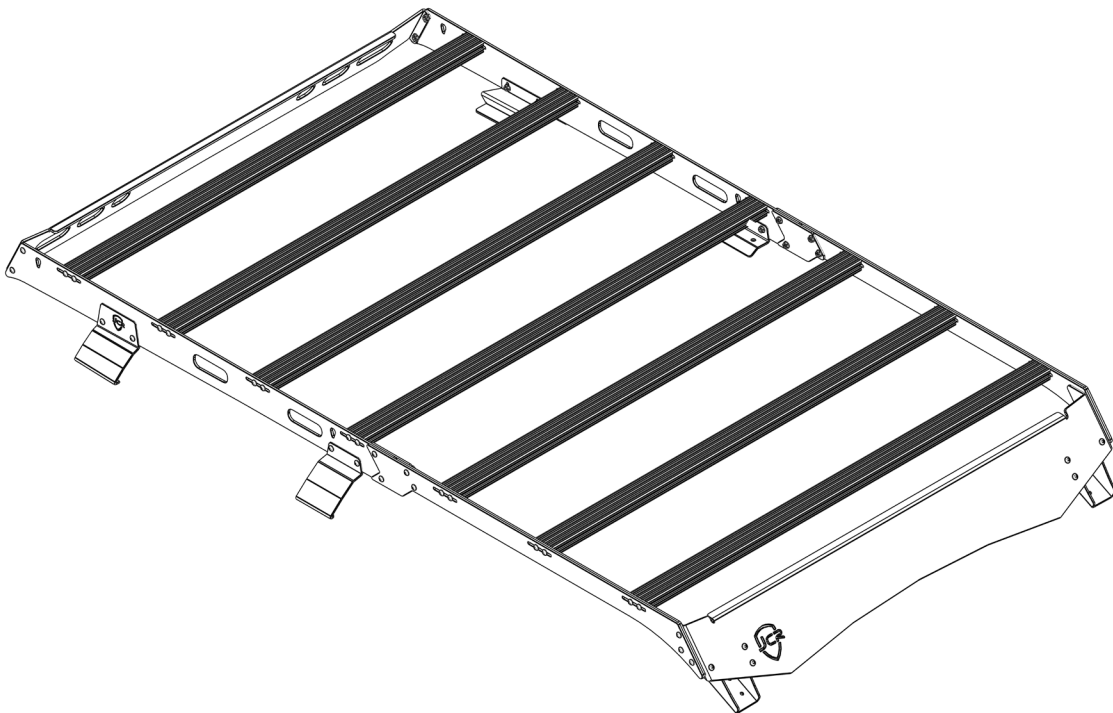

**Please read the mounting instructions below carefully before attempting to install.**

**Check out the install video on the product page for factory rack disassembly.**

Thank you for purchasing from JcROffroad! Checkout our website, [www.jcroffroad.com](http://www.jcroffroad.com) for other great off-road products. Be sure to rate and review our product online. If you have any questions or are missing parts, please don't hesitate to call us at 269-353-1184!

# INCLUDED HARDWARE

52x

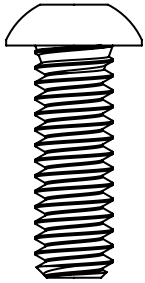

1/4"-20 X 3/4"  
Button Head (Silver)

4x

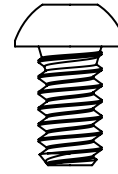

1/4"-20 X 3/8"  
Button Head  
Included with light  
bar cutout option.

6x

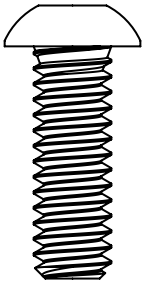

1/4"-20 X 3/4"  
Button Head (Black)

4x



1/4"-20  
T-Nut  
Included with light  
bar cutout option.

8x

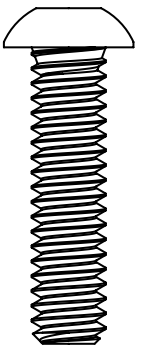

1/4"-20 X 1"  
Button Head (Black)

32x

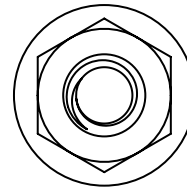

1/4"-20  
Serr. Flange Nut

66x

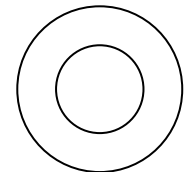

1/4" ID  
Washer

# INCLUDED PARTS

2x

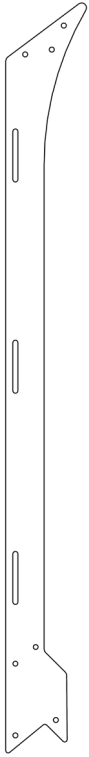

2x

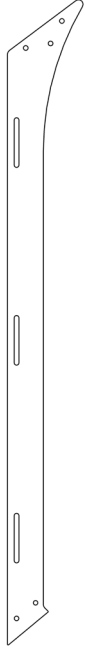

2x



7x



1x



1x



1x

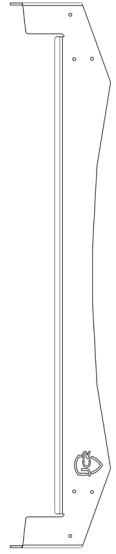

Or

2x



1L/1R

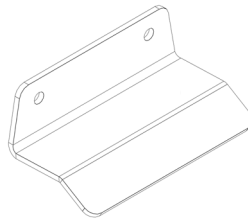

1L/1R

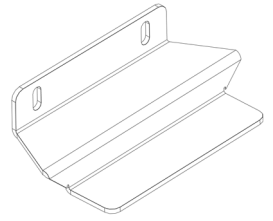

1L/1R

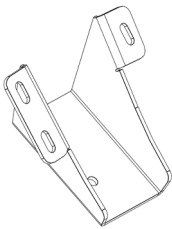

1L/1R

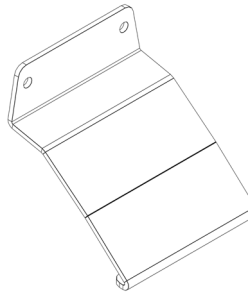

1L/1R

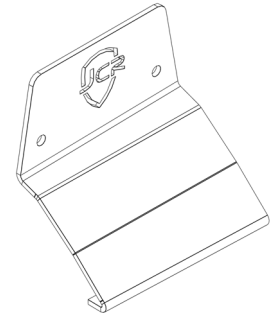

1L/1R



Included with light bar cutout option.



# ASSEMBLY

- 1 Start by mounting four crossbars between the two wider side rails. For this, use the 1/4"-20 X 3/4" button head bolts and the 1/4" ID washers (2 per bar per side). Make sure the machined slot in the rail of the crossbar is facing up so you can easily add t-nuts to mount your gear.

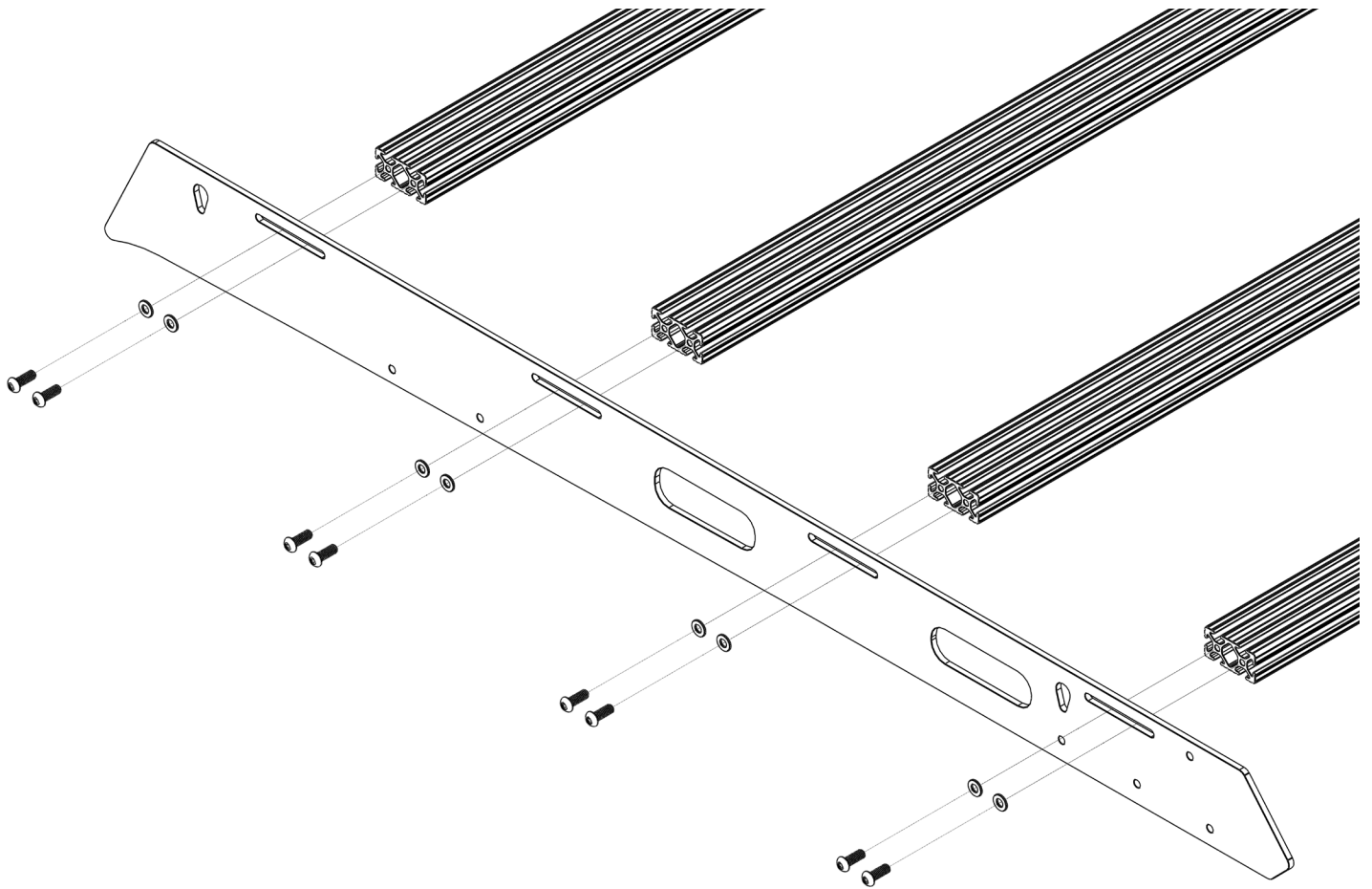

# ASSEMBLY

- 2** Next, find the inner mounts labeled R and M. The inner mounts are the ones with the sharper angles. Apply one of the provided rubber sheets to the bottom of each of them, making sure that the rubber hugs the bracket tightly across the entire bottom. For visual aid on this step, check out 1:55 (R) and 19:20 (M) in the instruction video at the bottom of the rack's product page.
- 3** Once the rubber is on each mount, loosely attach them to the inside of the side rails using the 1/4"-20 X 3/4" button head bolts, 1/4" ID washers and 1/4"-20 serr. flange nuts. The R mounts go towards the rear. Each mount should have an arrow pointing towards the front. With the mounts in place, set the rack on the hard top with each R mount sitting flat in the indentations on the hard top.

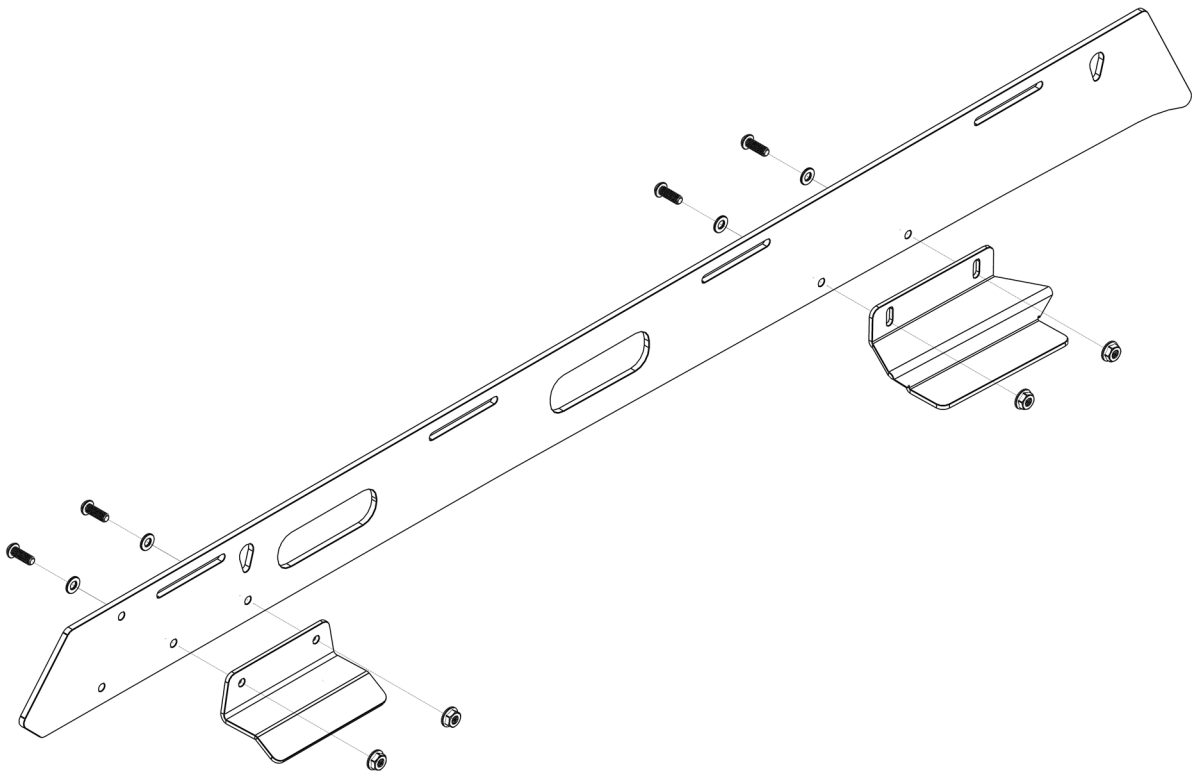

# ASSEMBLY

- 4** Next, find the outer R mounts and attach more of the rubber sheets the bottom of each, similar to the inner mounts. Be sure to cover the top of the hook portion as well. For visual aid on this step, check out 5:20 in the instruction video at the bottom of the rack's product page.
- 5** Once the rubber is in place, remove the hardware holding the inner R mounts in place and loosely install the outer R mounts using that hardware. They mount to the outside of the side rails through the same holes as the inner mounts and the bottom hook flange slides into the cutouts in the side of the hardtop above the windows. The arrows should be pointing towards the front. Once everything is loosely in place, tighten them fully while making sure that the inner mounts are pushed down tight to the surface of the roof.

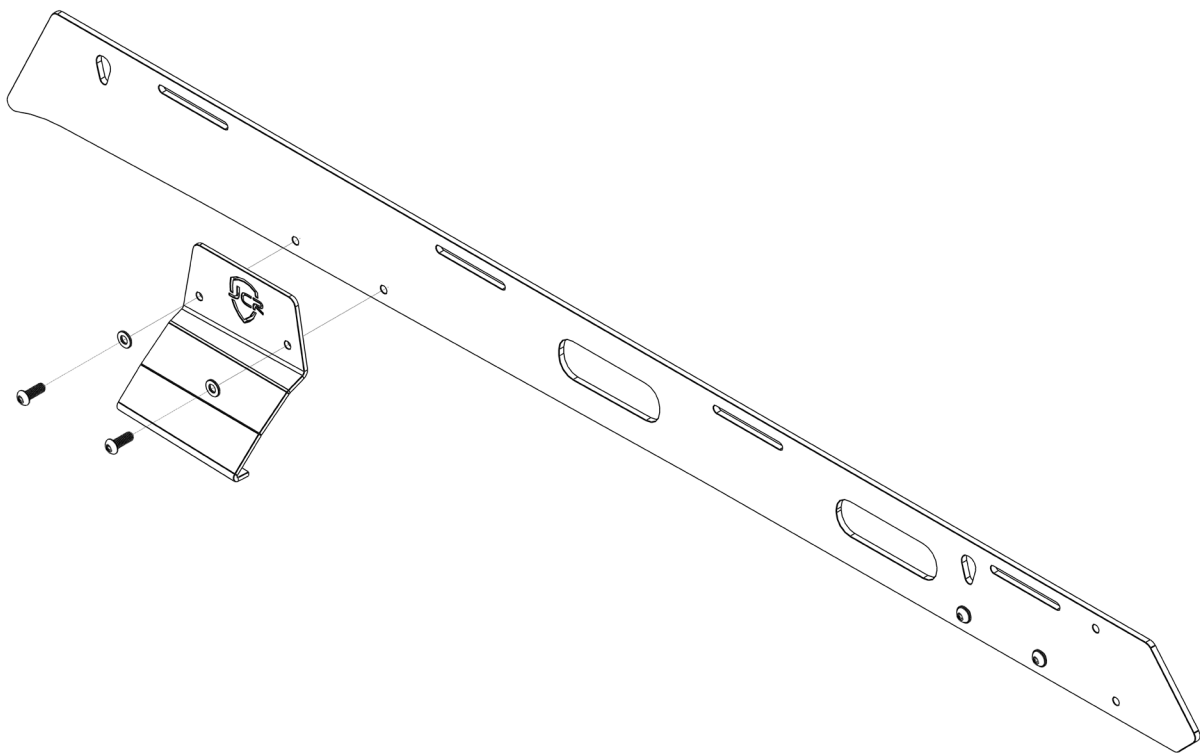

# ASSEMBLY

- 6** With the rear portion of the rack installed, you can begin to work on the front portion. Start by removing the accessory ready caps above the front windshield and then remove the plastic piece underneath using a 10mm socket. With those out of the way, you can place the front mounts into place in each of them. The arrows should point forward, and the single holed flange should be on the outside. Take care not to over tighten the nut when reinstalling.
- 7** Once the front mounts are in place, you will need to make some modifications to the covers and plastic pieces before you reinstall them. For the black plastic pieces, you will need to cut a few tabs and a ridge from the bottom of each so they can sit flat against the mounts. The covers will also need to be cut to fit over the mounts. The easiest way to do this is to make a straight cut from the front to the back just to the inside of the outside edge. If you want a little bit of a cleaner look, you can take the time to only cut where it contacts the mount. Some trimming of the inside edge may be required as well.
- 8** With the modifications made, place the black plastic pieces into place on top of the mounts and fasten them both in place using the factory nuts. Then simply pop the covers back into place.

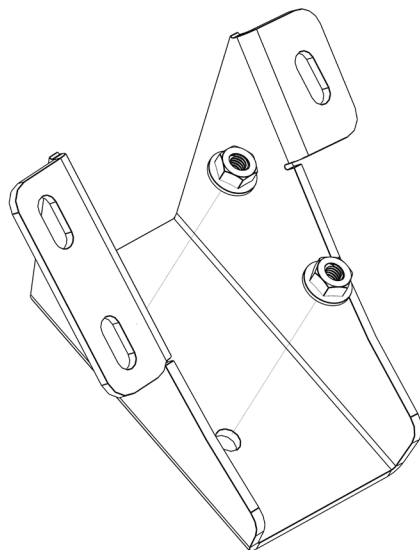

# ASSEMBLY

- 9** Next, mount the strip of trim to the bottom edge of the front fairing. Start just to the outside of the peak of the bottom edge and continue until it reaches the equivalent point on the other side of the fairing. Cut off any extra. Then, do the same thing for the rear fairing using the other piece of trim.

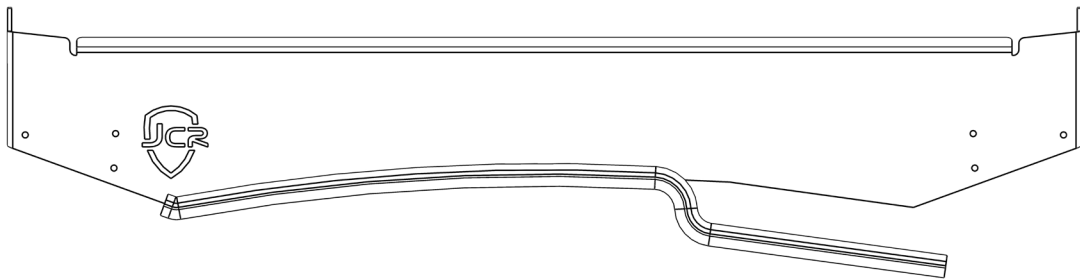

- 10** Next, loosely assemble the side rails as shown below. The longer side rail goes on the outside and the small bracket goes on the inside. They all bolt into place using a 1/4"-20 X 1" button head bolt, 1/4" ID washer and 1/4"-20 serr. flange nut in each of the front two holes.

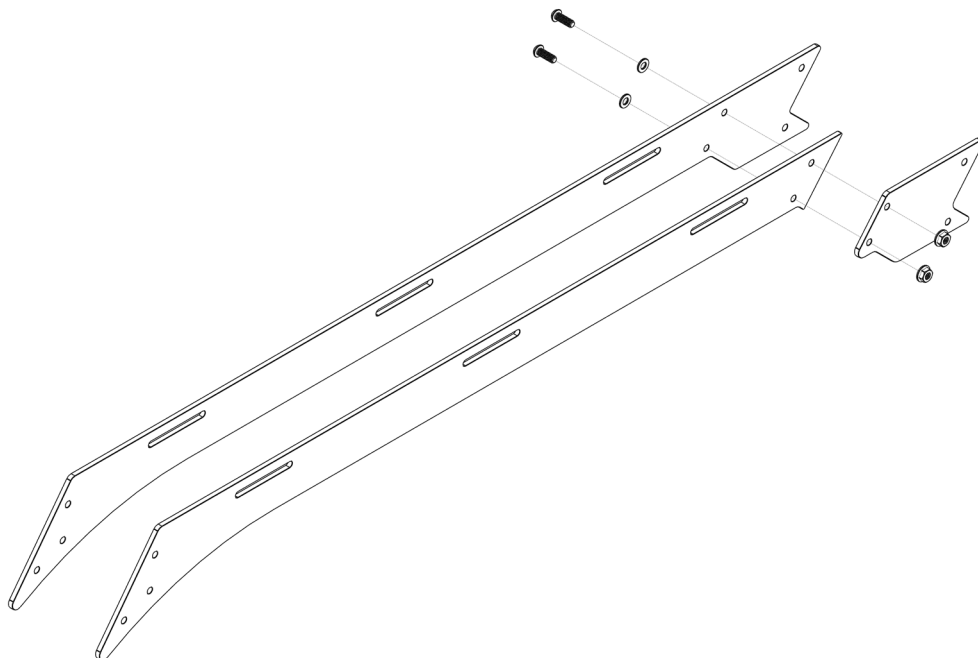

# ASSEMBLY

- 11** Once the components are assembled, loosely mount the front fairing to the front mounts using the 1/4"-20 X 3/4" button head bolts, 1/4" ID washers and 1/4"-20 serr. flange nuts. We recommend applying clear 3M paint protection film to the roof of the vehicle anywhere the edge trim/fairings make contact with the roof. This will protect the paint from dirt/debris over time.

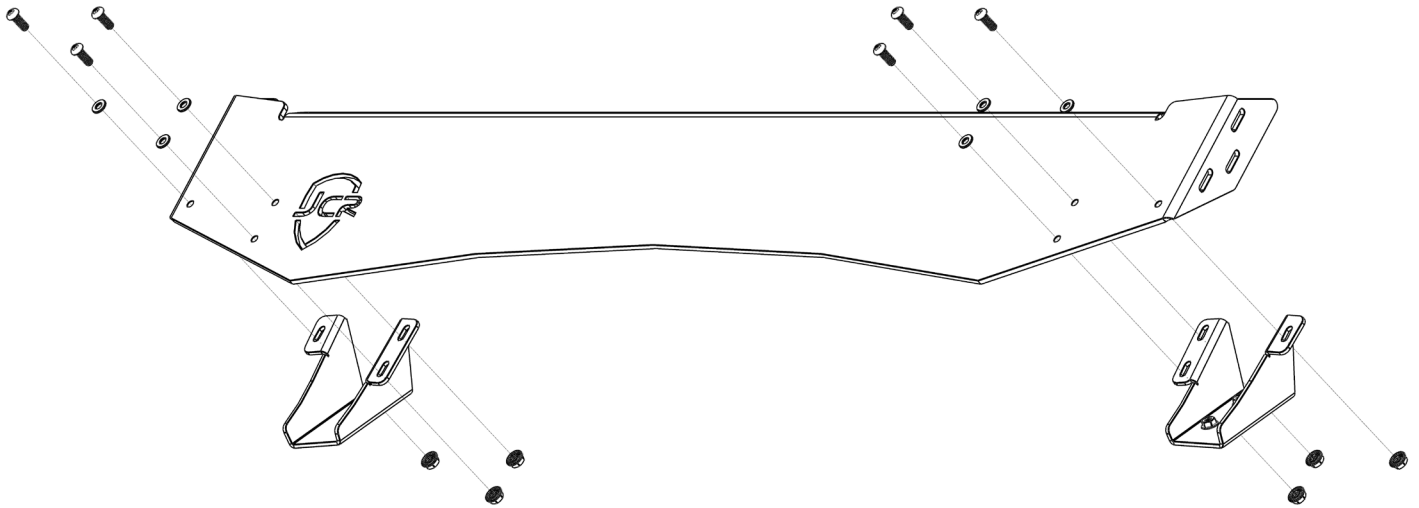

# ASSEMBLY

- 12** With the front fairing in place, loosely mount the side rails into place using the silver 1/4"-20 X 3/4" button head bolts into the fairing, black 1/4"-20 X 1" button head bolts into the bracket, 1/4" ID washers and 1/4"-20 serr. flange nuts. The front of the rails bolt onto the outside edges of the front fairings while the rear slides over and sandwiches the front edge of the rear side rails. Once everything is loosely assembled, go back and tighten all the hardware in to place. Make sure the front fairing sits tight to the roof.

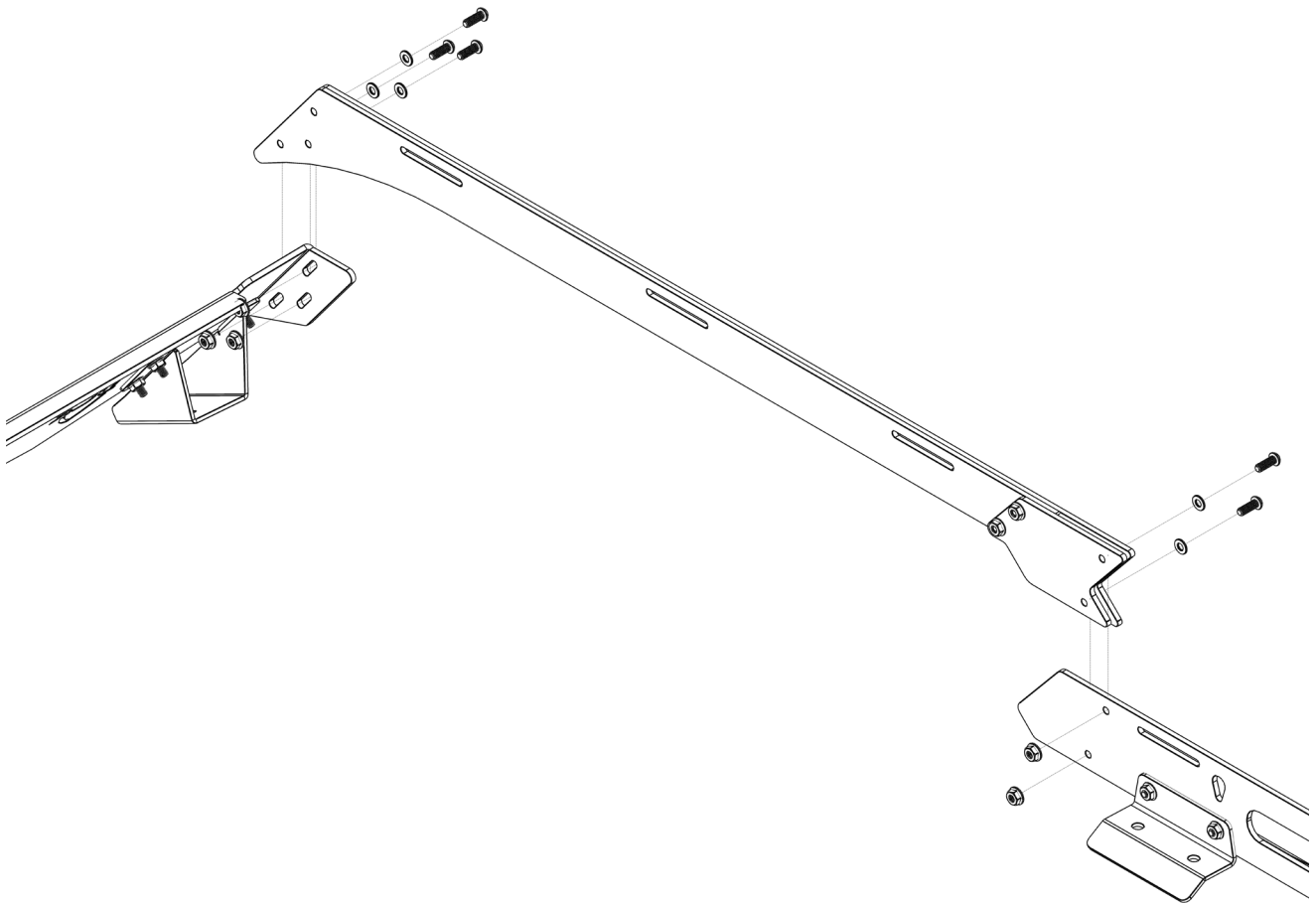

# ASSEMBLY

- 13** After the side rails are in place, you can install the remaining cross bars between them using the 1/4"-20 X 3/4" button head bolts and 1/4" ID washers. Make sure the machined slot in the rail of the crossbar is facing up so you can easily add t-nuts to mount your gear.

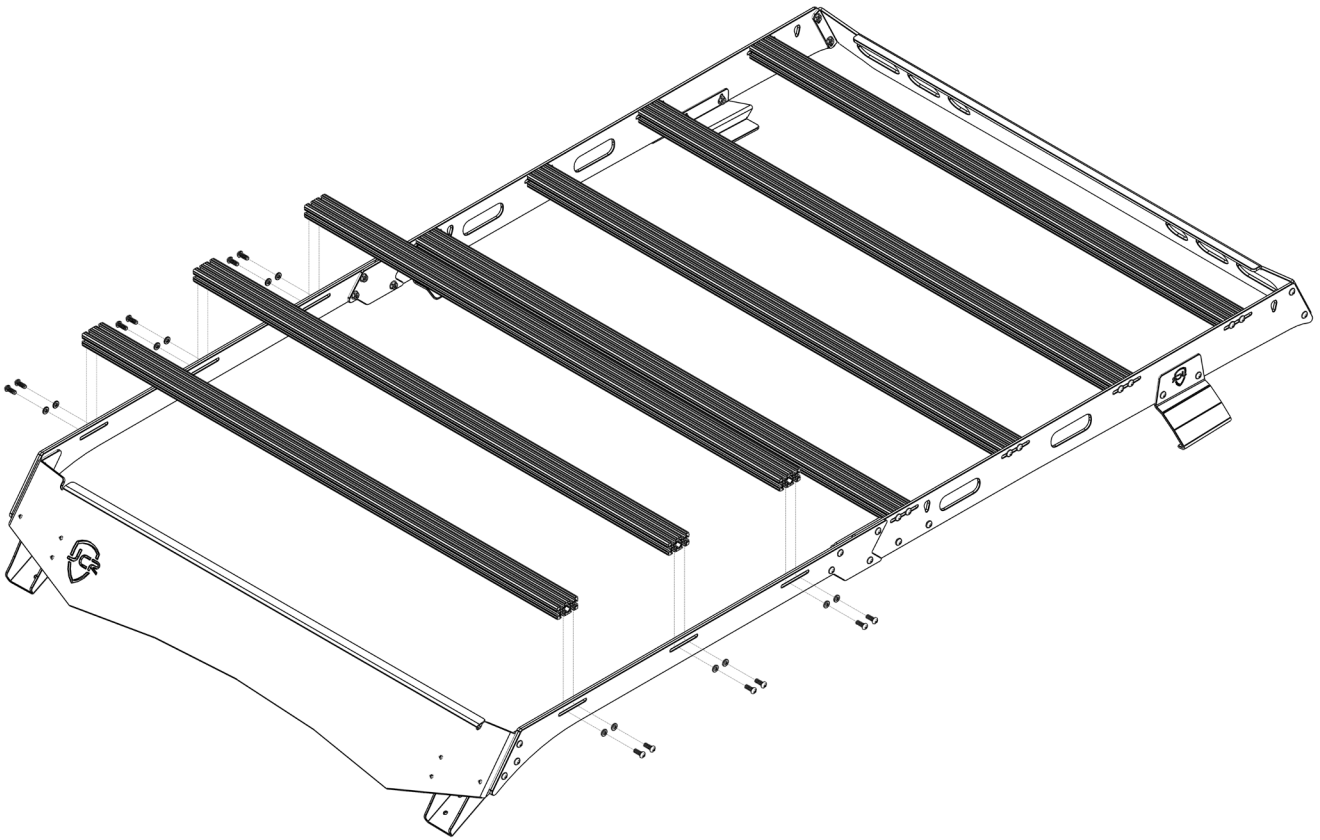

- 14** Next, install the rear fairing between the rear side rails using the 1/4"-20 X 3/4" button head bolts, 1/4" ID washers and 1/4"-20 serr. flange nuts. Once it is loosely in place, push it tight to the roof and tighten it into place.



# ASSEMBLY

- 15** Finally, with the rack secured into position, find the outer M mounts and attach the remaining rubber sheets the bottom of each. On these mounts, do not cover the hooked portion with the rubber because it will not fit into position if you do so. For visual aid on this step, check out 18:50 in the instruction video at the bottom of the rack's product page. You can then bolt them onto the rack using the hardware that is holding the inner M mounts in place. Make sure to slip the hooked portion of the mounts into the small slot in the hardtop, similar to the way the R mounts install, except without the extra cutout to locate it. The arrows should point towards the front of the vehicle.

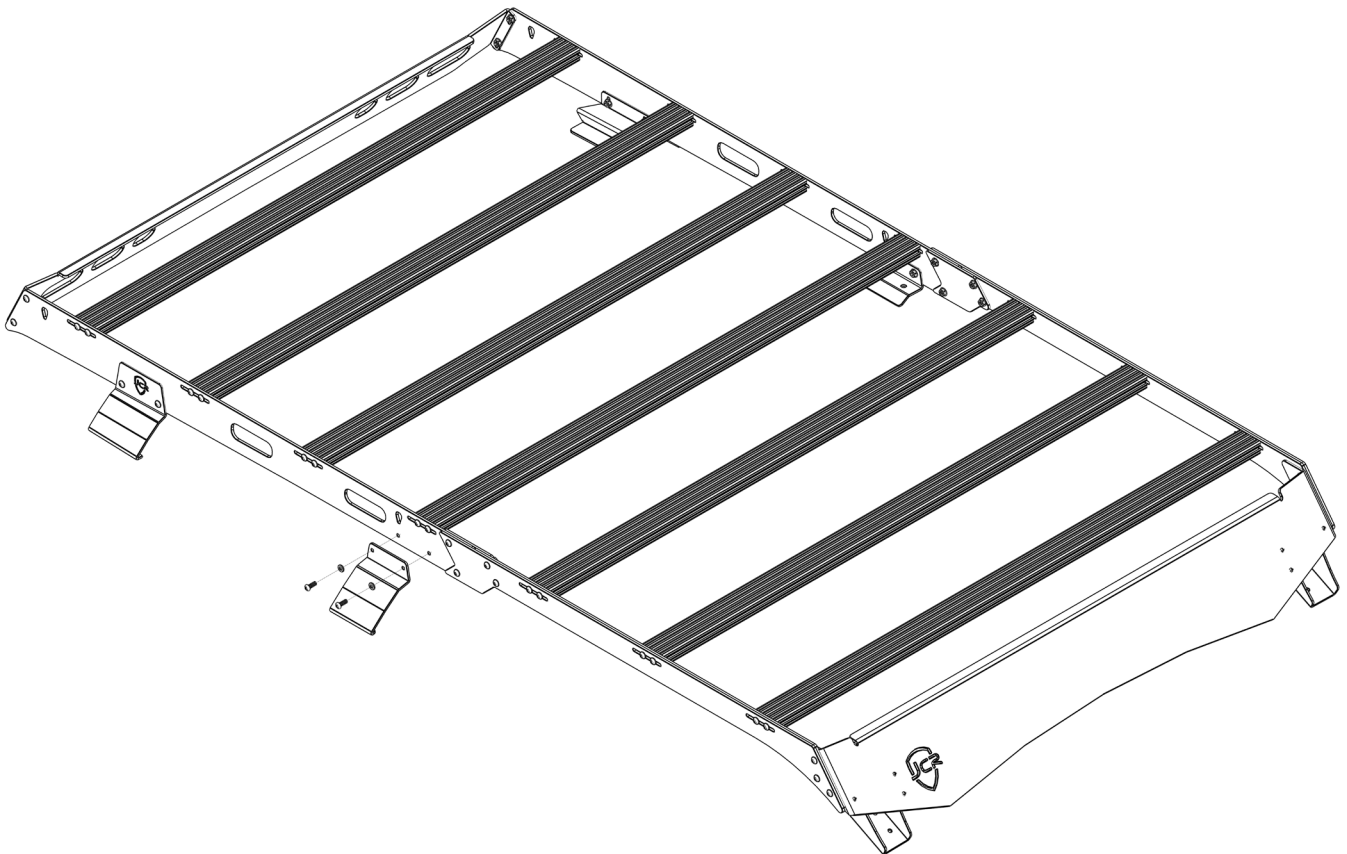

# DIMENSIONS

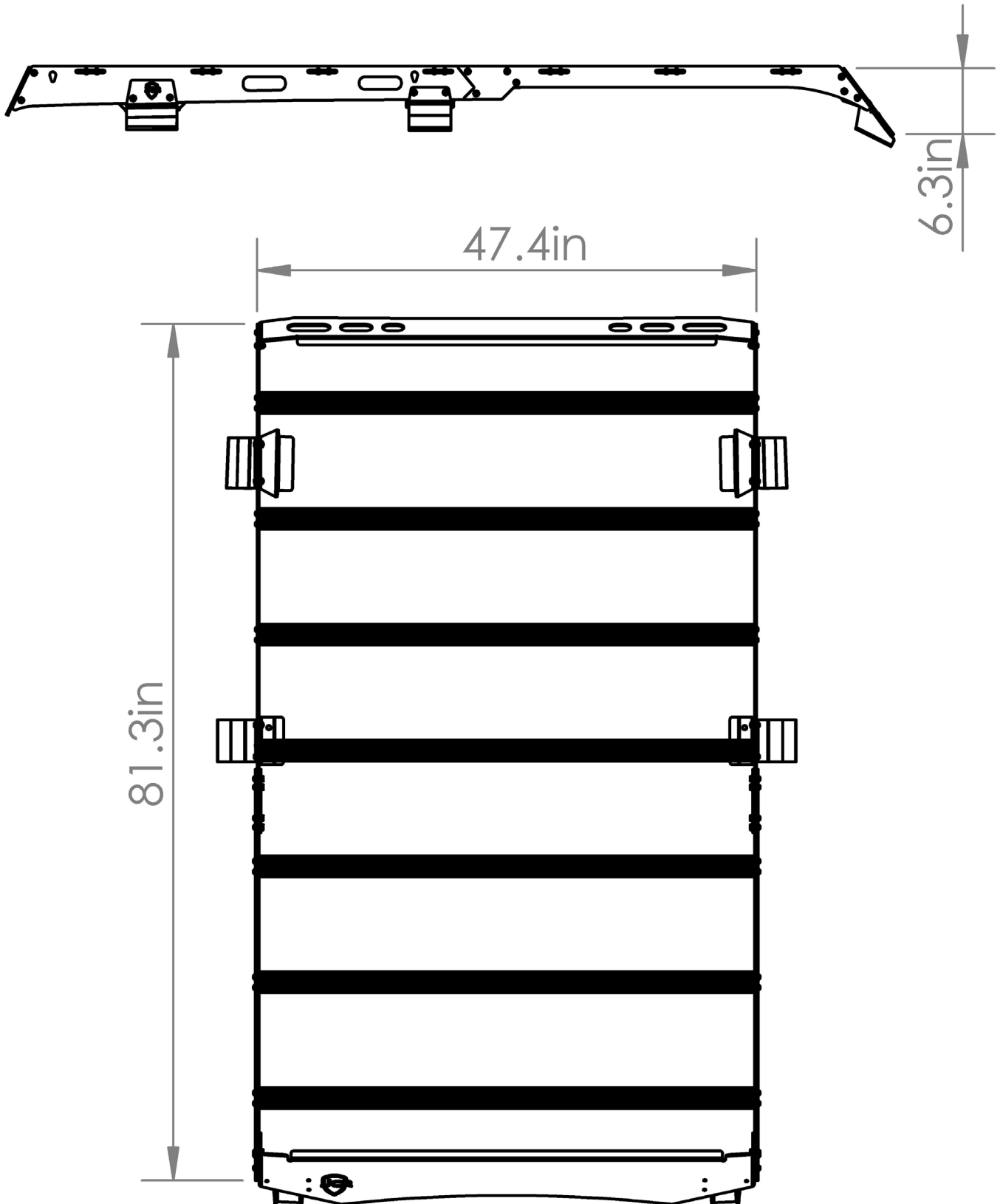

# 40" LIGHT BAR ASSEMBLY

- 1** Slide 2 t-nuts into each of the channels on the top side of the front-most crossbar using the slots. Then, place each light bar mount over one pair of t-nuts and loosely bolt it in place using the 1/4"-20 X 3/8" button heads.

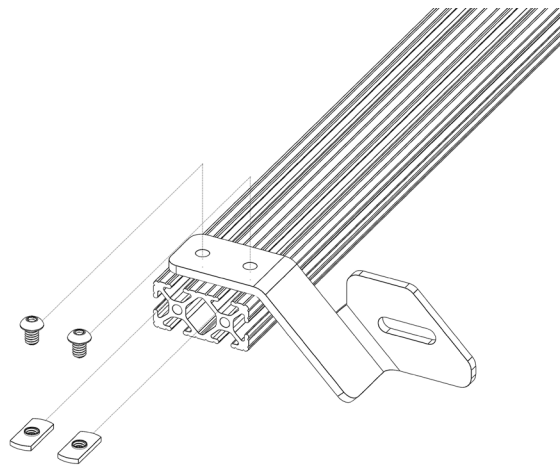

- 2** Next, place your light bar between the mounts and mount it in the slots using the hardware provided with the light bar. After that is firmly in position, make any adjustments to the positioning necessary to center the light bar on the rack. Depending on the rack and light bar, you may need to adjust the position of the cross bar in its slot as well.

