



TABLE OF CONTENTS

JK FULL ROOF RACK.....	2
JK SHORT ROOF RACK.....	14
2 DOOR JK ROOF RACK.....	25



JK FULL ROOF RACK

INSTALL INSTRUCTIONS

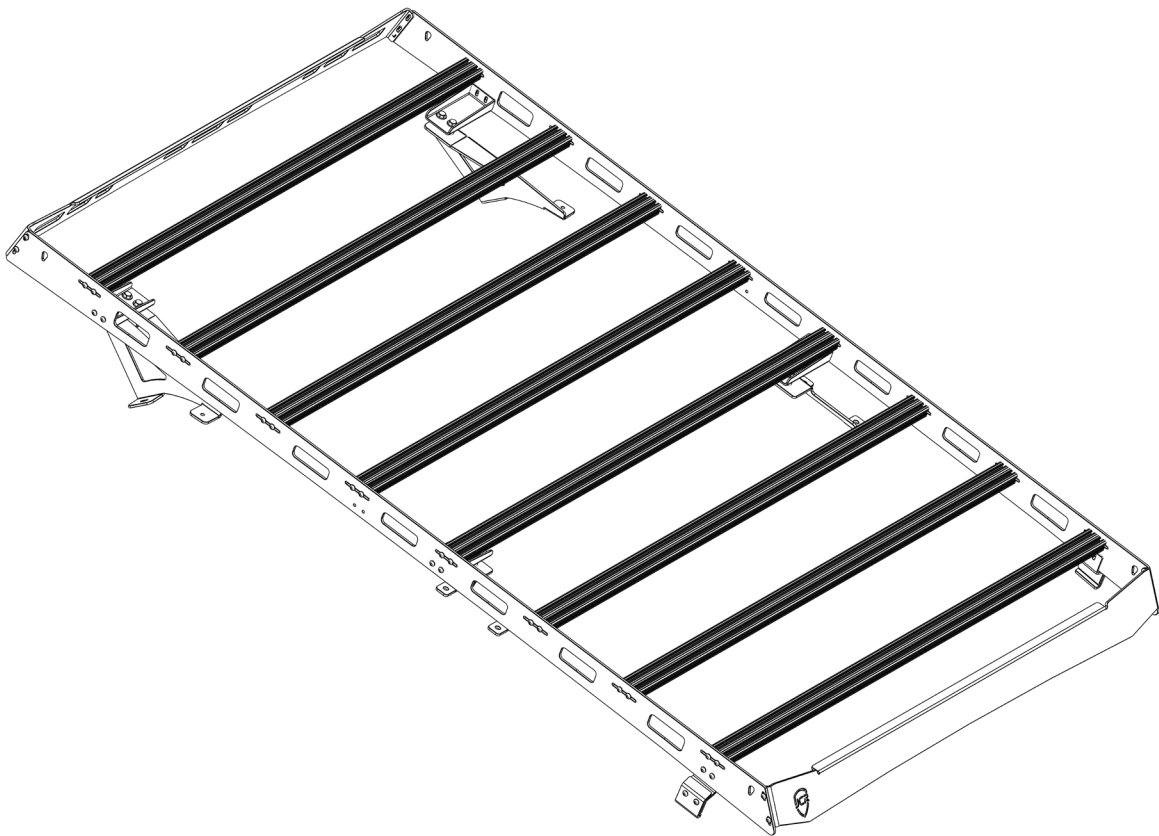

Please read the mounting instructions below carefully before attempting to install.

Check out the install video on the product page for factory rack disassembly.

Thank you for purchasing from JcROffroad! Checkout our website, www.jcroffroad.com for other great off-road products. Be sure to rate and review our product online. If you have any questions or are missing parts, please don't hesitate to call us at 269-353-1184!

INCLUDED HARDWARE

56x

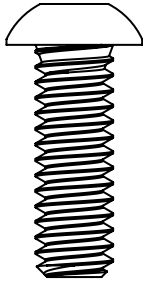

1/4"-20 X 3/4"
Button Head

8x

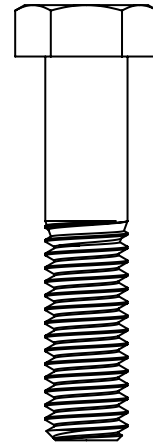

3/8"-16 X 1-3/4"
Hex Head

24x

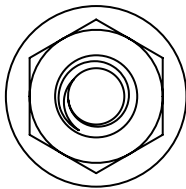

1/4"-20
Serr. Flange Nut

8x

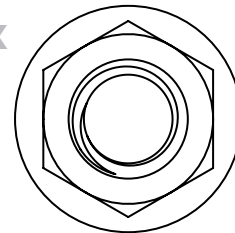

3/8"-16
Serr. Flange Nut

56x

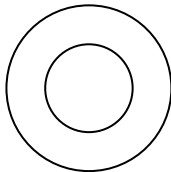

1/4" ID
Washer

8x

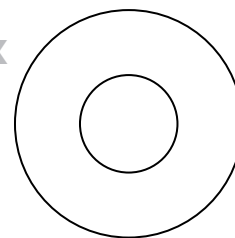

5/16"
USS Washer

4x



1/4"-20 X 3/8"
Button Head
Included with light
bar cutout option.

4x



1/4"-20
T-Nut
Included with light
bar cutout option.

8x

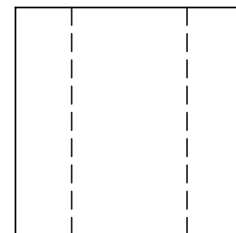

3/8" ID X 3/4"
Aluminum Unthreaded
Spacer

INCLUDED PARTS

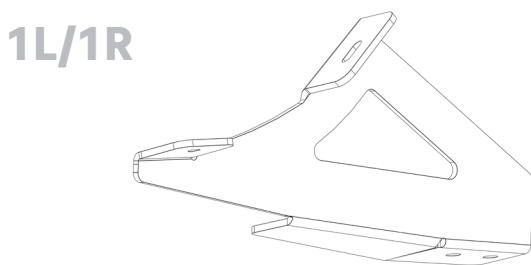
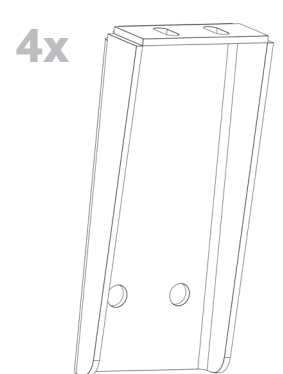
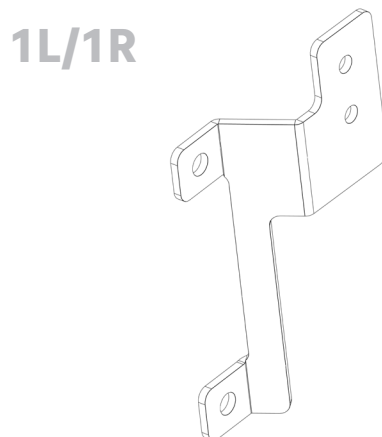
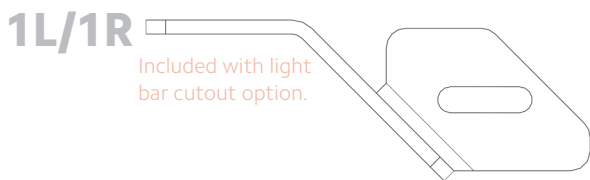
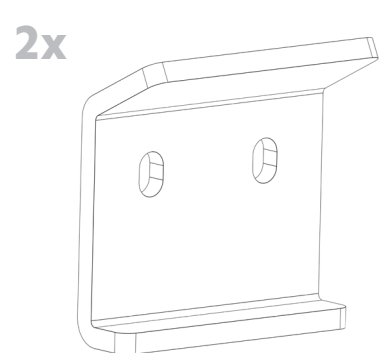
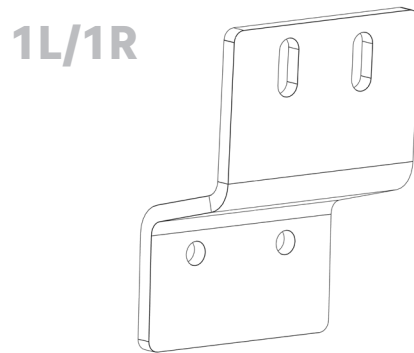
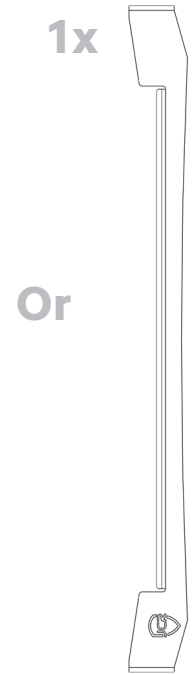
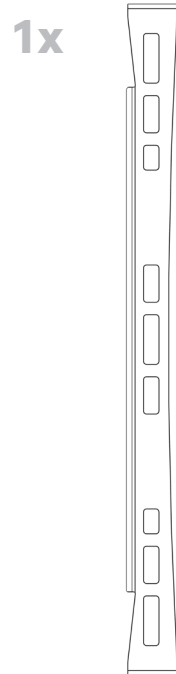
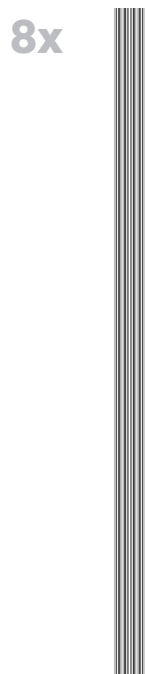
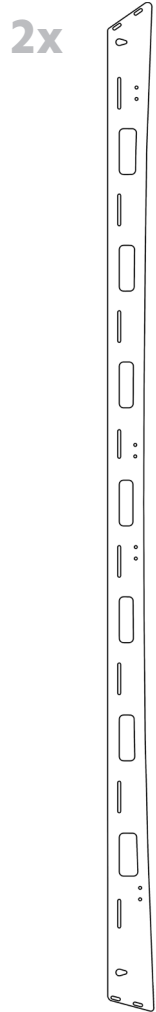

ASSEMBLY

- 1** Assemble the rack on the ground. Start by mounting the crossbars between the two side rails. For this, use the 1/4"-20 X 3/4" button head bolts and the 1/4" ID washers (two per bar per side). Make sure the machined slot in the rail of the crossbar is facing up, so that you can easily add t-nuts to mount your gear.

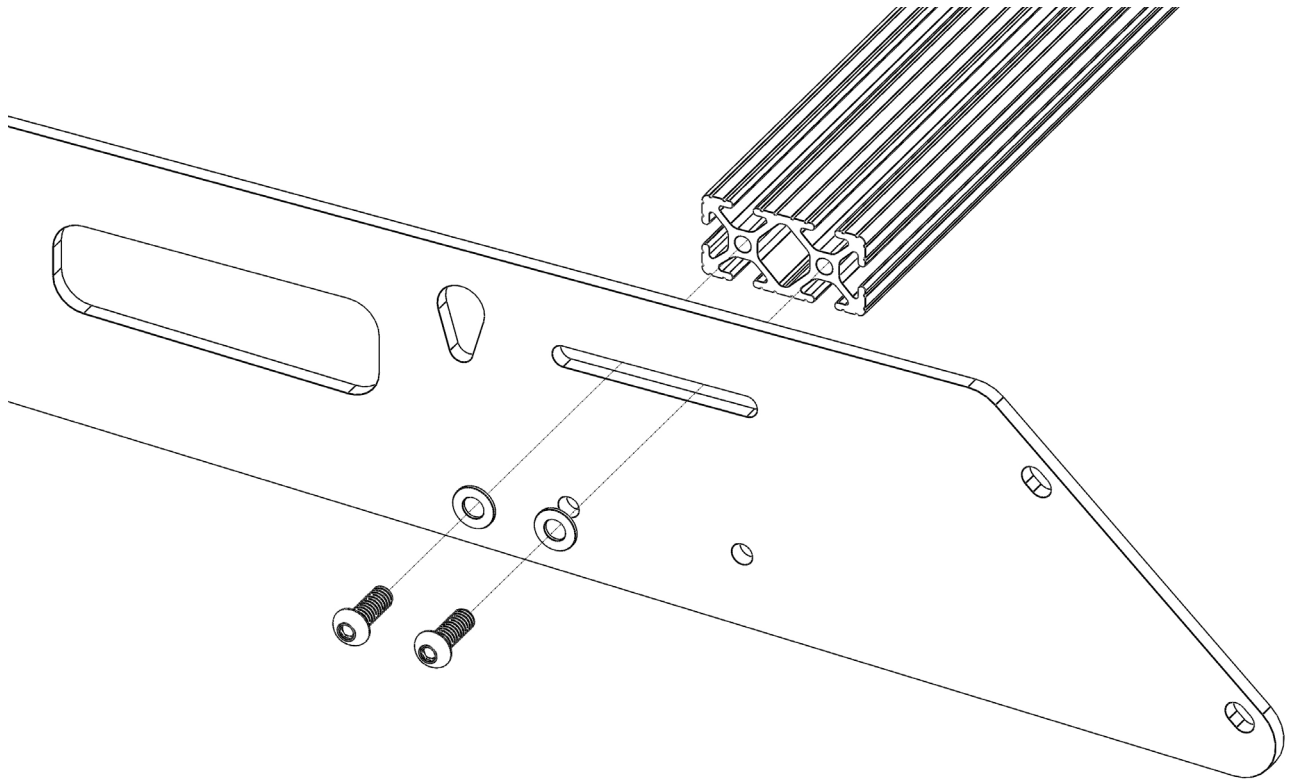

ASSEMBLY

- 2** Next, mount the strip of trim to the bottom edge of the front fairing. Start just to the outside of the peak of the bottom edge and continue until it reaches the equivalent point on the other side of the fairing. Cut off any extra. Then, mount the extra piece onto the bottom edge of the rear fairing in the center.

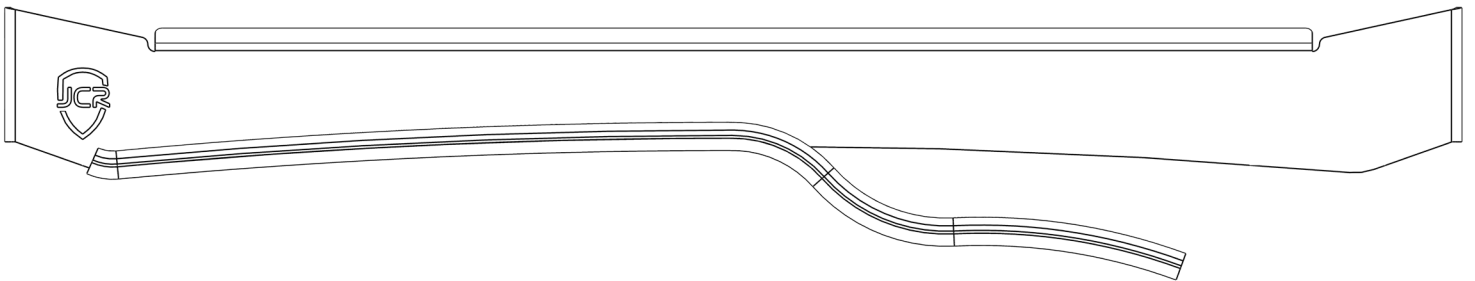

ASSEMBLY

- 3** Next, mount the front and rear fairings. To do this, use the 1/4"-20 X 3/4" button head bolts, 1/4" ID washers, and 1/4"-20 serrated flange nuts. The front fairing will need two of each per side and the rear fairing will also need two of each per side. When mounting the front fairing, adjust it all the way up to avoid contact with the roof and leave the bolts loose enough to be able to make adjustments once it is on the roof of the vehicle.

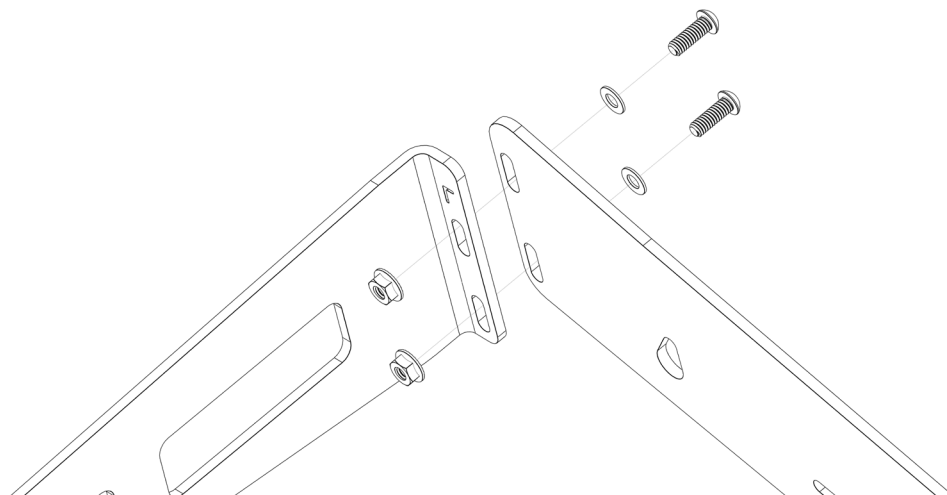
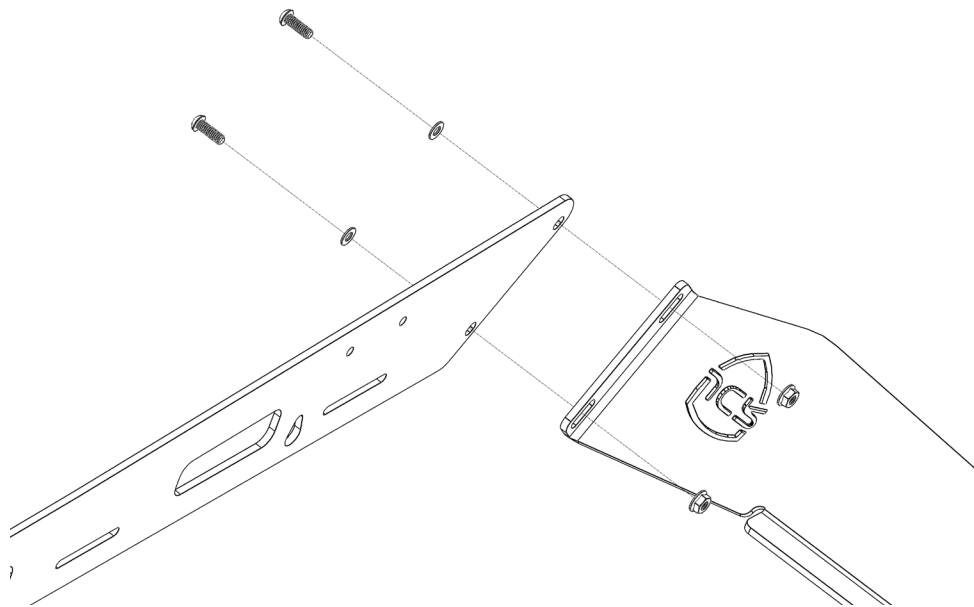

ASSEMBLY

- 4** Next you will need to cut some slots in your roll bar padding and attach the support brackets to the vehicle. Watch the instruction video to see how and where you should cut the slots. Once you have them cut, slide the bracket through them and mount them using the factory holes and factory hardware already in the roll bar.

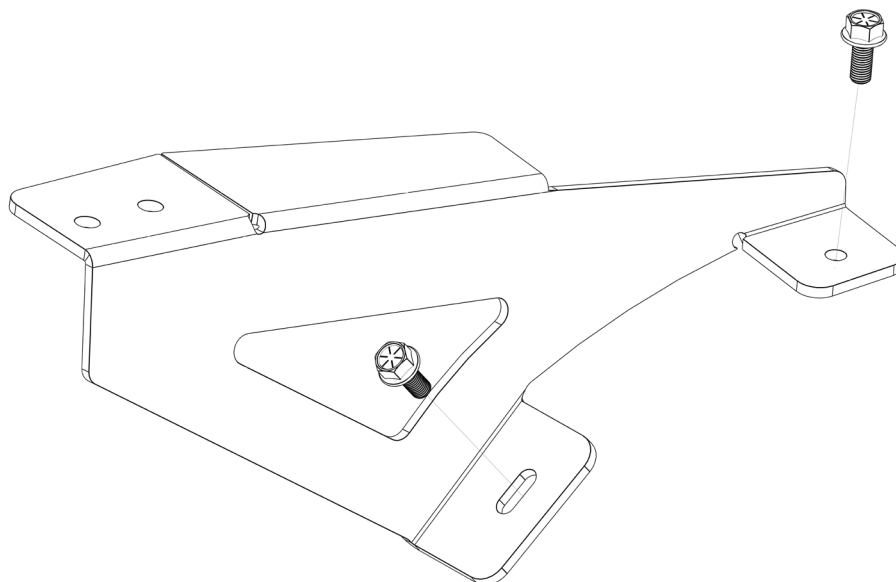
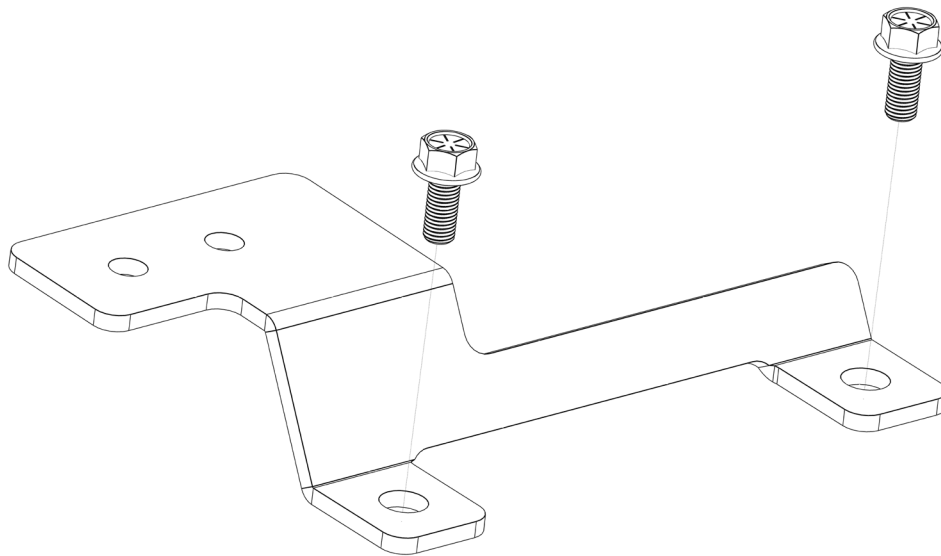

ASSEMBLY

- 5** Next, attach the mounts to the assembled roof rack using the 1/4"-20 X 3/4" button head bolts, 1/4" washers and 1/4" serrated flange nuts. Set the mounts at the lowest position and tighten them for now to give the most clearance. Before attaching the front mounts, cut the small edge trim to size and put it on the bottom edge of each.

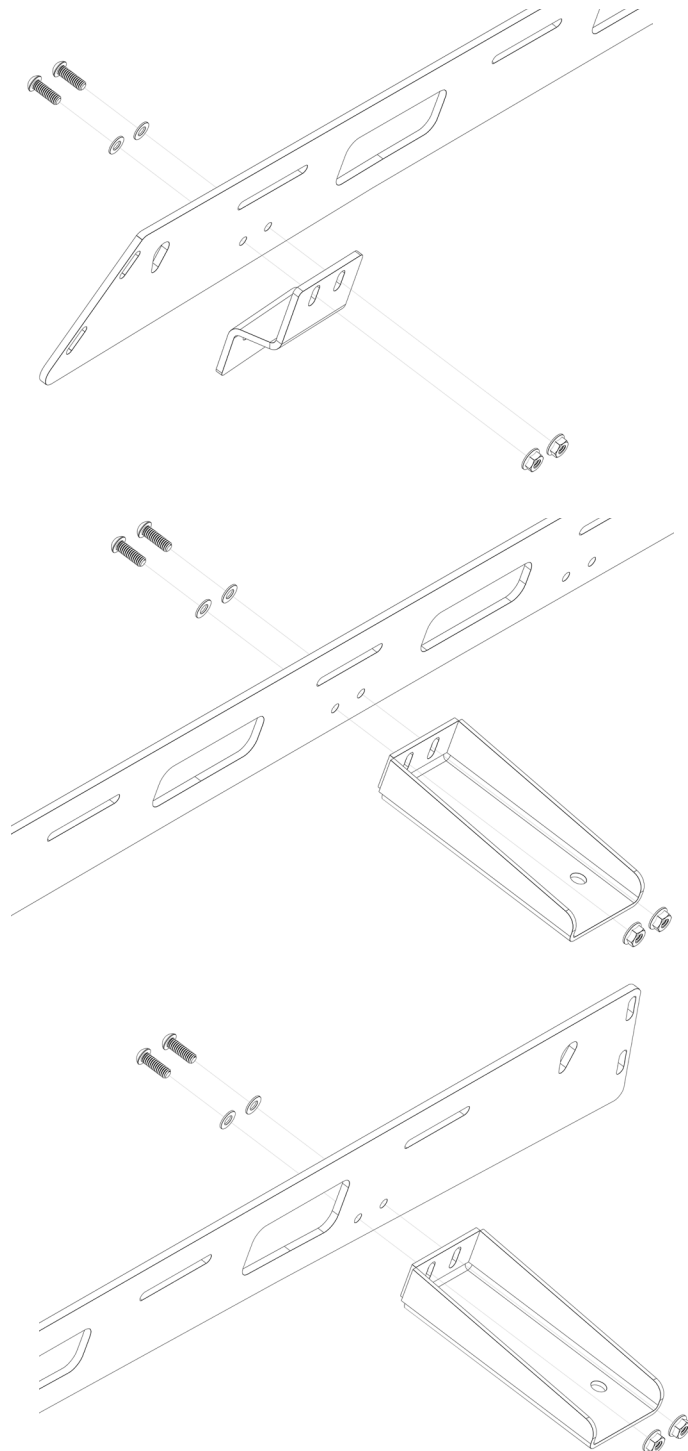

ASSEMBLY

- 7** Next, watch the instruction video for instructions on drilling the holes in your roof. With those drilled, put some RTV around each hole and insert an aluminum spacer into each hole.
- 8** Now that everything is ready, put RTV around the hole in the aluminum spacers and place the assembled rack into position on the roof of the vehicle. It helps to put a bolt through one hole in one of the rear mounts in order to get the rack into the correct position. Make sure that both front mounts are seated firmly in the rain gutters.
- 9** Next, attach the mid and rear mounts to the roof of the vehicle. Start by putting more RTV around and over each of the mounting holes so that the bolts will have to pass through it. Then, bolt the rack into the roof using the 3/8"-16 X 1-3/4" hex head bolts and 5/16" USS washers on the top of the vehicle and the 3/8"-16 serr. flange nuts on the inside.

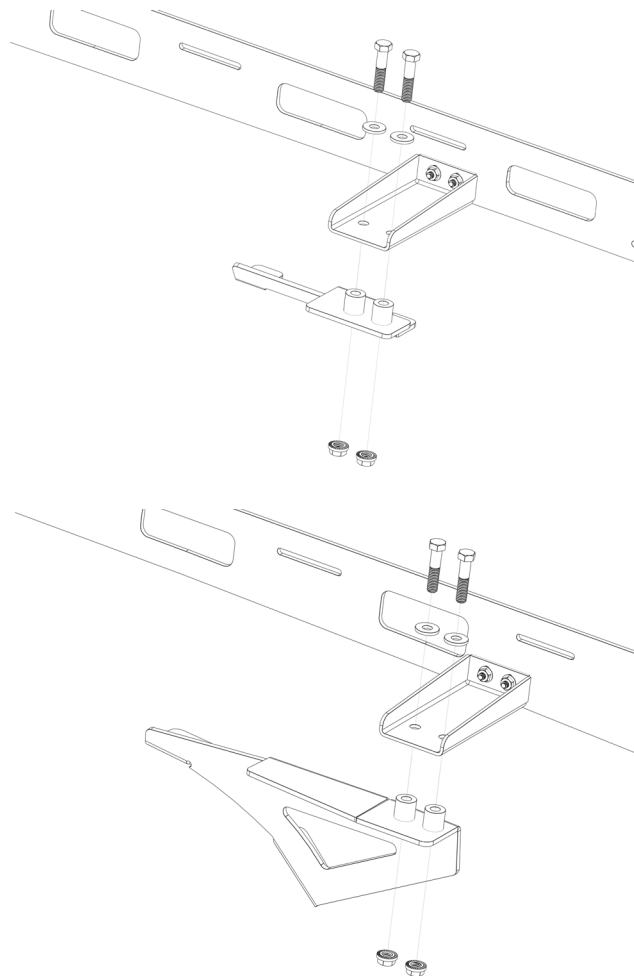

ASSEMBLY

- 10** Next, clamp the front mount into place. Place the clamp bracket over the front mount so that the larger flange is over the top of the mount and the smaller flange is under the bottom of the rain gutter. Then, clamp it firmly into place using the 1/4"-20 X 3/4" button head bolts, 1/4" ID washers, and 1/4"-20 serrated flange nuts.

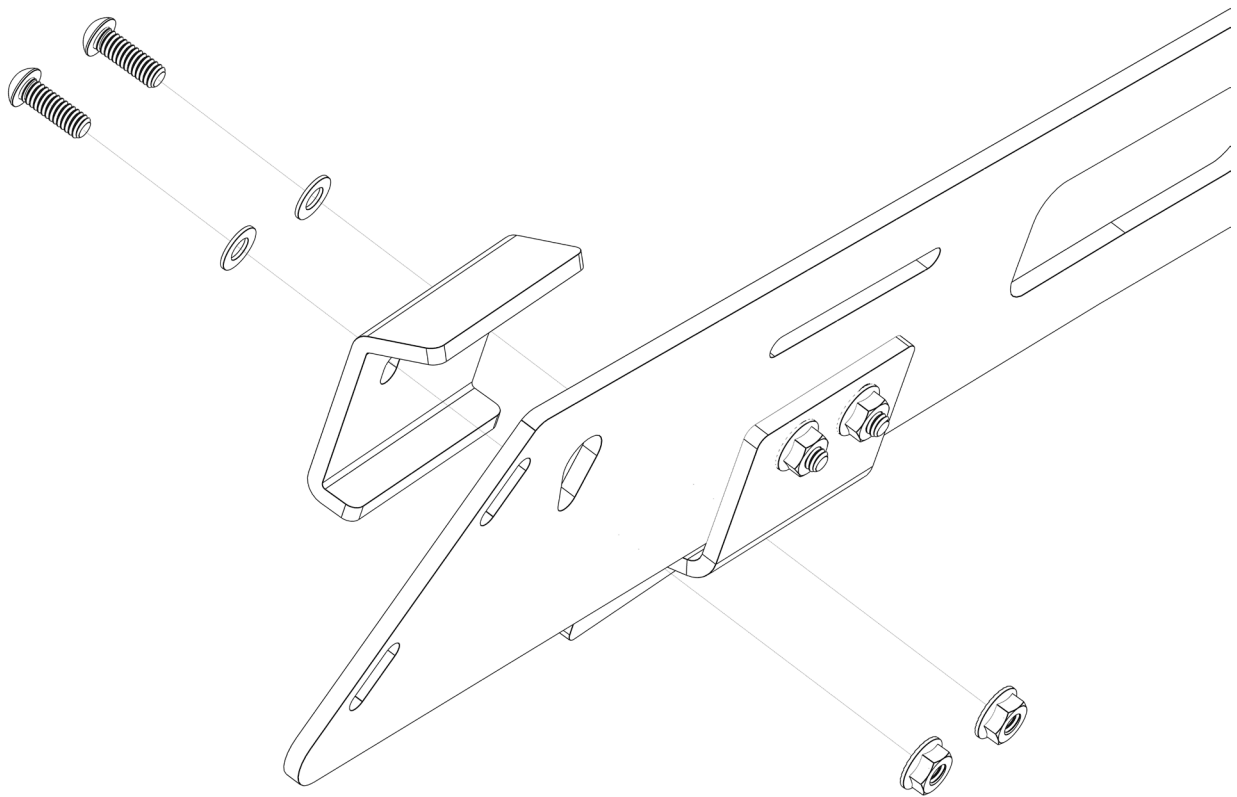

- 11** With everything roughly in place, make any adjustments to the mounts that are necessary to get an equal gap between the bottom of the side rails and the vehicle down the length of the roof and tighten them fully against the side rails.
- 12** Finally, push the front and rear fairing down tight to the roof of the vehicle and tighten everything fully into place. We recommend applying clear 3M paint protection film to the roof of the vehicle anywhere the edge trim/fairings make contact with the roof. This will protect the paint from dirt/debris over time.

40" LIGHT BAR ASSEMBLY

- 1** Slide two t-nuts into each of the channels on the top side of the front-most crossbar using the slots. Then, place each light bar mount over one pair of t-nuts and loosely bolt it in place using the 1/4"-20 X 3/8" button heads.

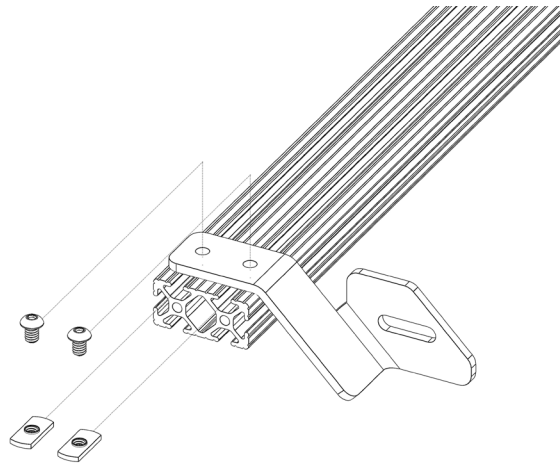

- 2** Next, place your light bar between the mounts and mount it in the slots using the hardware provided with the light bar. After that is firmly in position, make any adjustments to the positioning necessary to center the light bar on the rack. Depending on the rack and light bar, you may need to adjust the position of the cross bar in its slot as well.

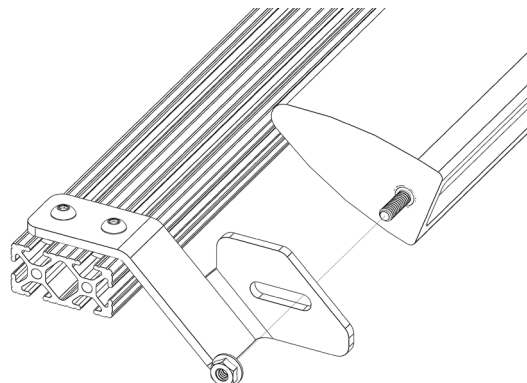

DIMENSIONS

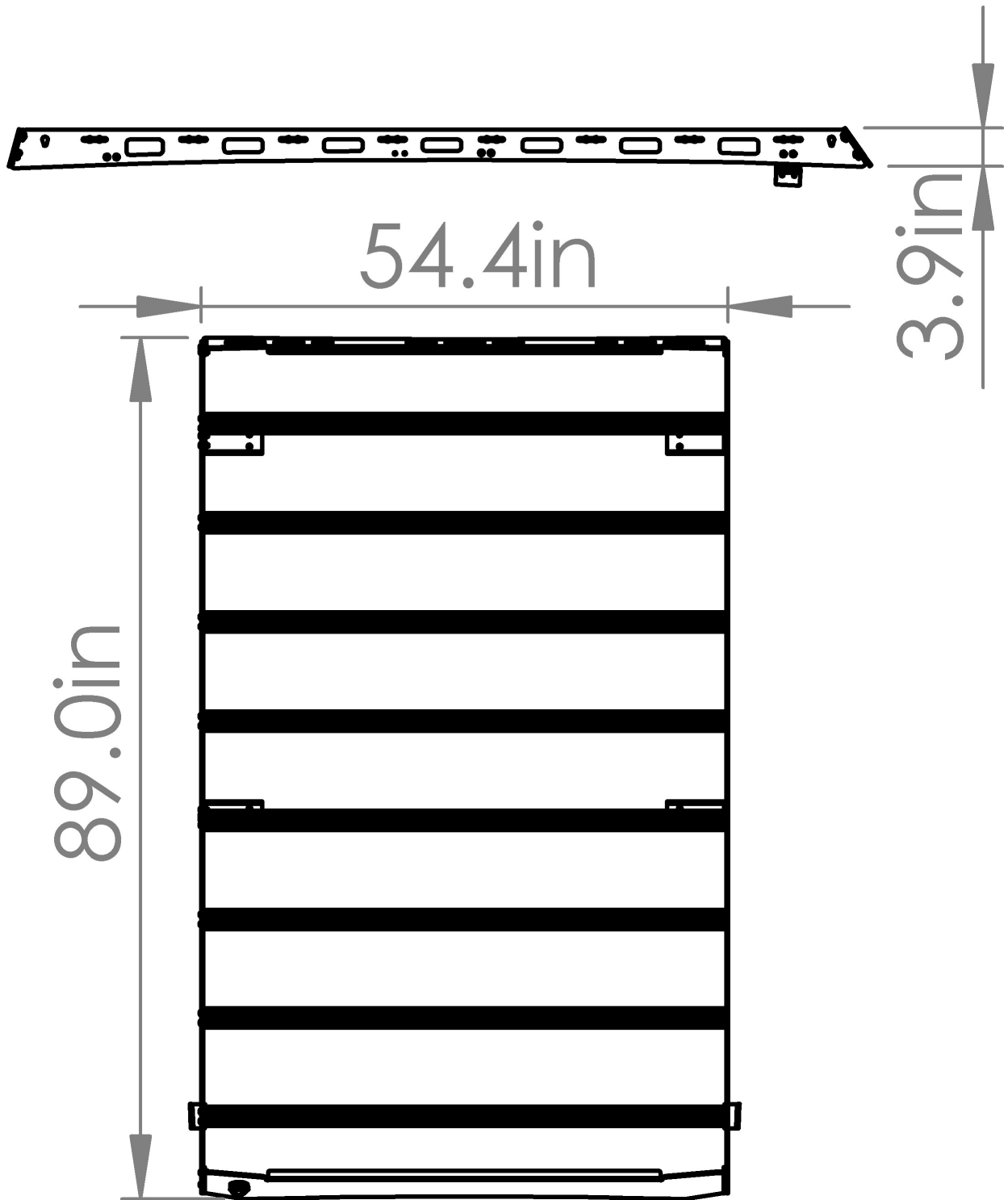



JK SHORT ROOF RACK

INSTALL INSTRUCTIONS

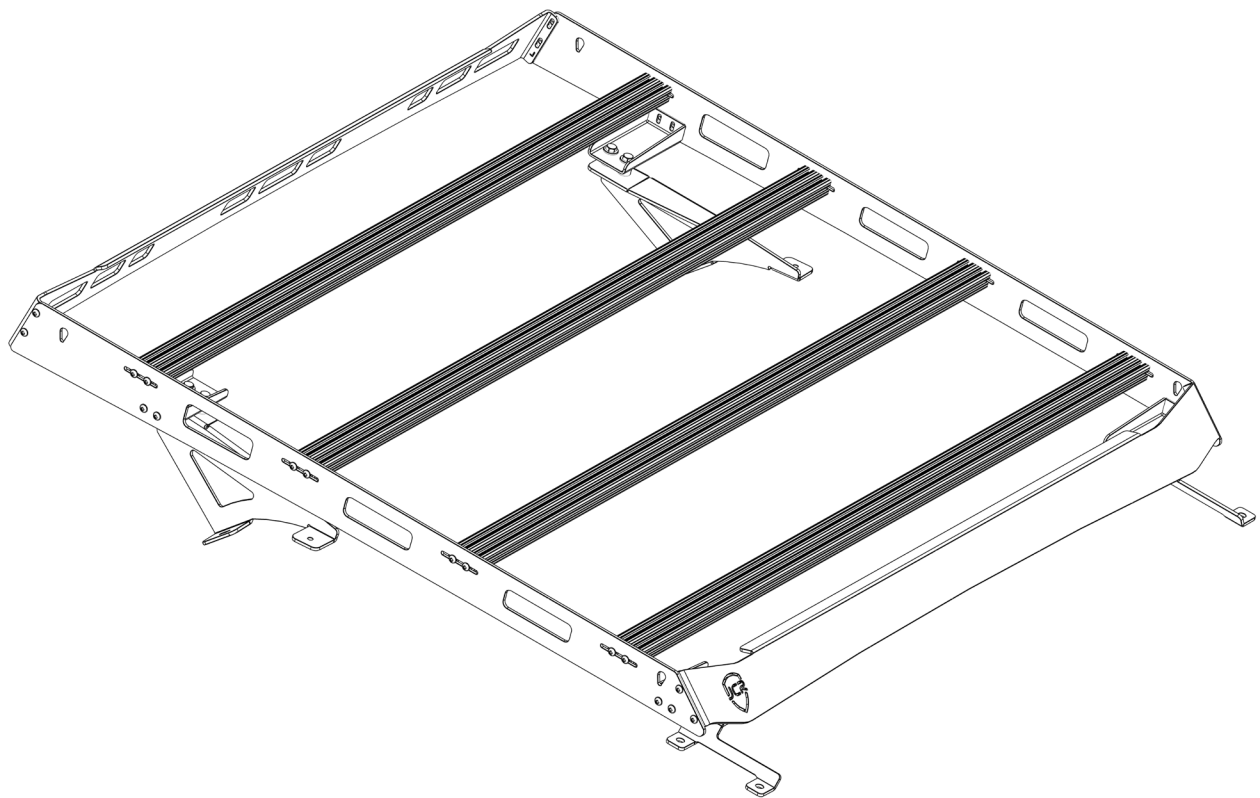

Please read the mounting instructions below carefully before attempting to install.

Check out the install video on the product page for factory rack disassembly.

Thank you for purchasing from JcROffroad! Checkout our website, www.jcroffroad.com for other great off-road products. Be sure to rate and review our product online. If you have any questions or are missing parts, please don't hesitate to call us at 269-353-1184!

INCLUDED HARDWARE

32x

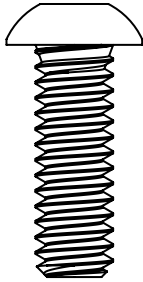

1/4"-20 X 3/4"
Button Head

8x

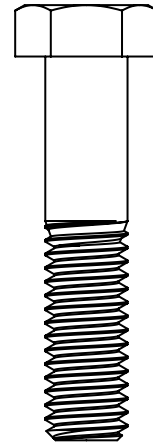

3/8"-16 X 1-3/4"
Hex Head

16x

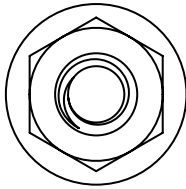

1/4"-20
Serr. Flange Nut

8x

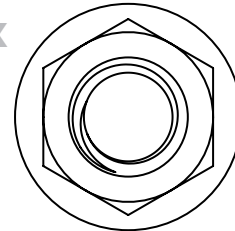

3/8"-16
Serr. Flange Nut

32x

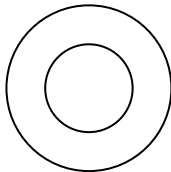

1/4" ID
Washer

8x

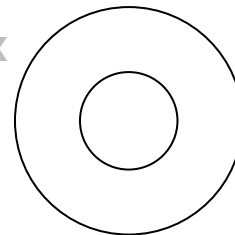

5/16"
USS Washer

8x

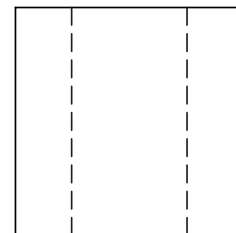

3/8" ID X 3/4"
Aluminum Unthreaded
Spacer

INCLUDED PARTS

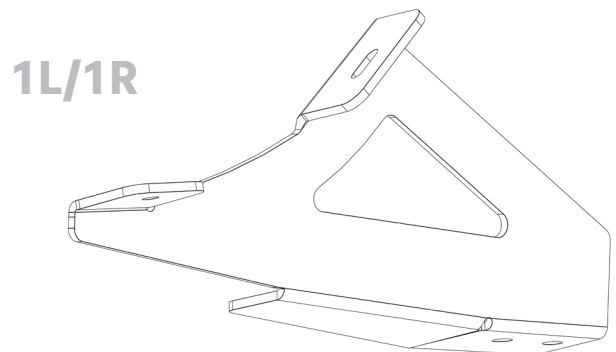
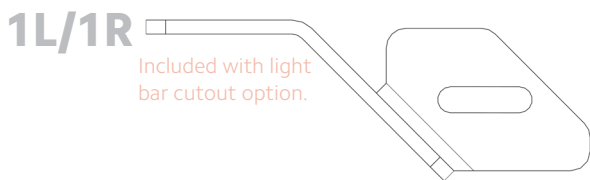
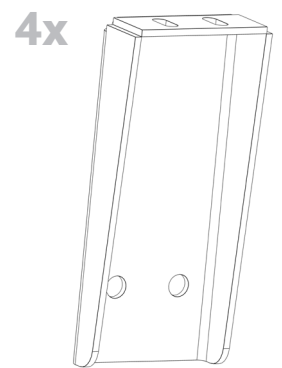
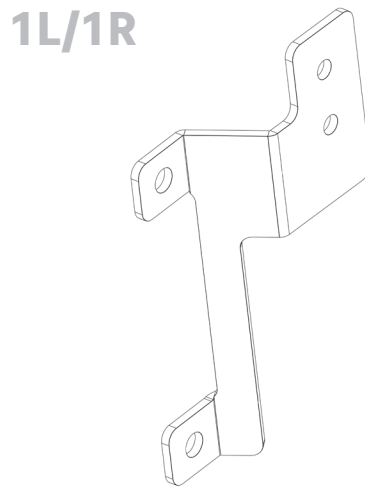
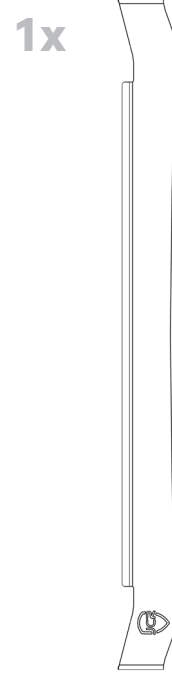
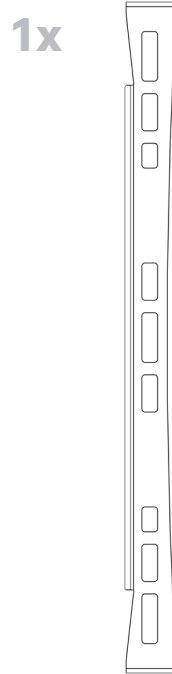
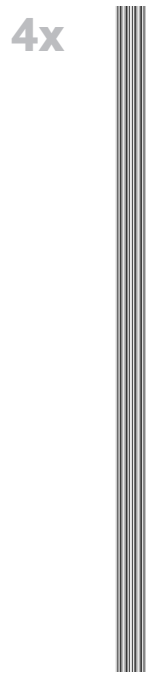
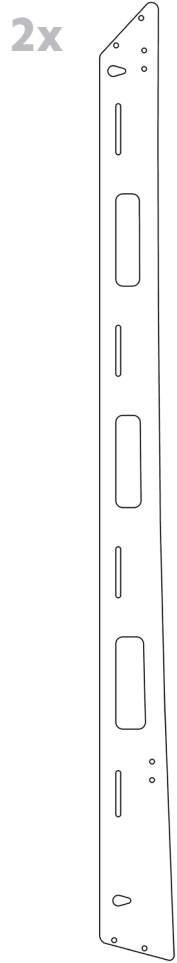

ASSEMBLY

- 1** Assemble the rack on the ground. Start by mounting the crossbars between the two side rails. For this, use the 1/4"-20 X 3/4" button head bolts and the 1/4" ID washers (two per bar per side). Make sure the machined slot in the rail of the crossbar is facing up, so that you can easily add t-nuts to mount your gear.

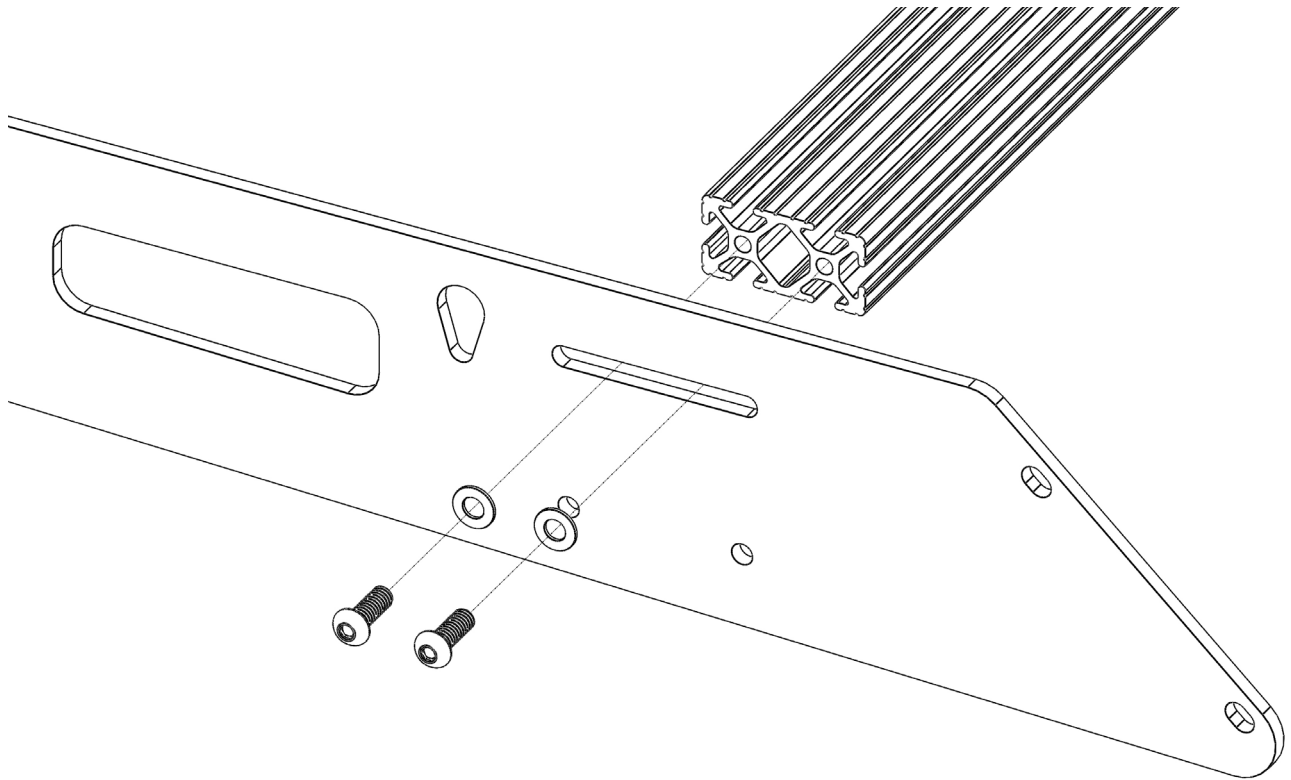

ASSEMBLY

- 2 Next, mount the strip of trim to the bottom edge of the front fairing. Start just to the outside of the peak of the bottom edge and continue until it reaches the equivalent point on the other side of the fairing. Cut off any extra. Then, mount the extra piece onto the bottom edge of the rear fairing in the center.

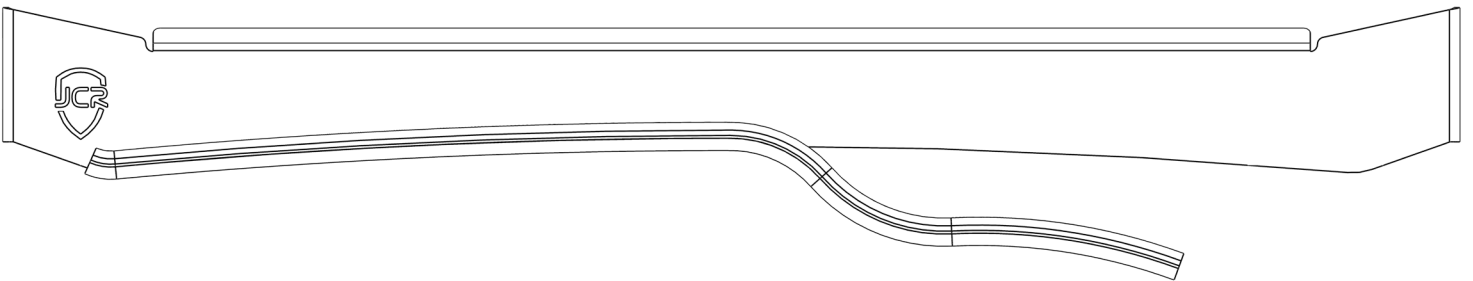

ASSEMBLY

- 3** Next, mount the front and rear fairings. To do this, use the 1/4"-20 X 3/4" button head bolts, 1/4" ID washers, and 1/4"-20 serrated flange nuts. The front fairing will need two of each per side and the rear fairing will also need two of each per side. When mounting the front fairing, adjust it all the way up to avoid contact with the roof and leave the bolts loose enough to be able to make adjustments once it is on the roof of the vehicle.

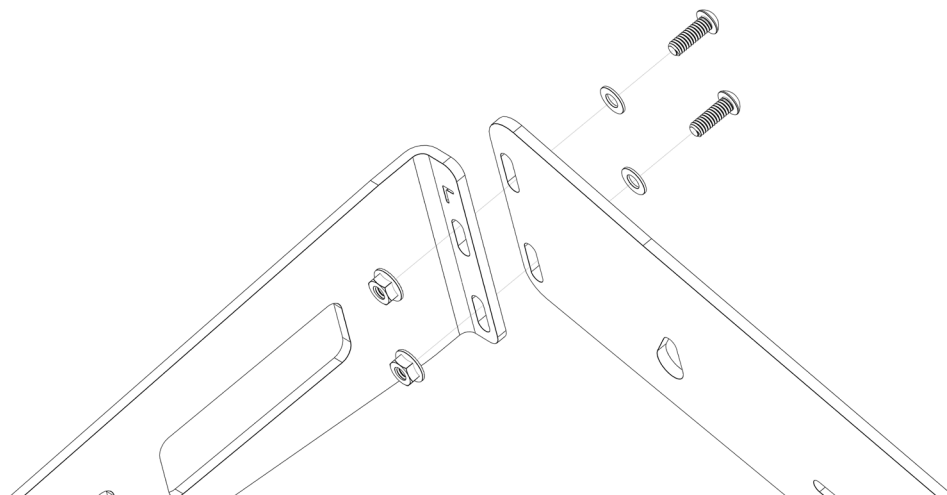
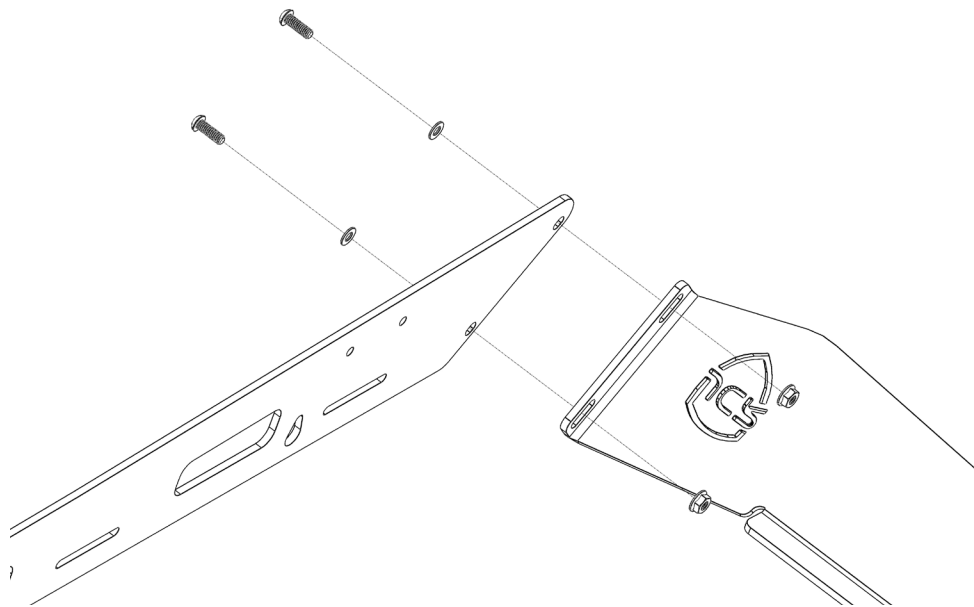

ASSEMBLY

- 4 Next, attach the mounts to the assembled roof rack using the 1/4"-20 X 3/4" button head bolts, 1/4" washers and 1/4" serrated flange nuts. Set the mounts at the lowest position and tighten them for now to give the most clearance.

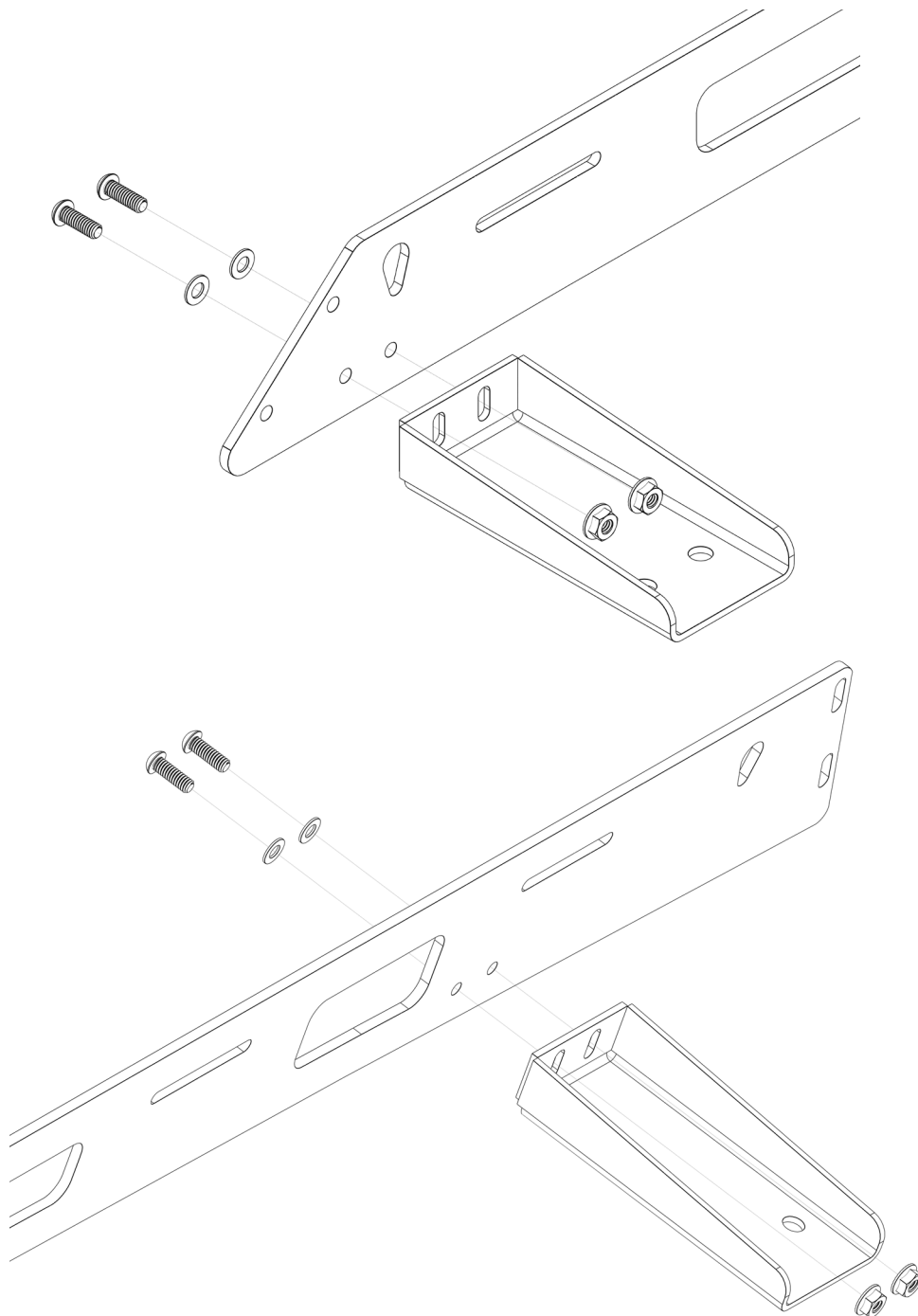

ASSEMBLY

- 5** Next you will need to cut some slots in your roll bar padding and attach the support brackets to the vehicle. Watch the instruction video to see how and where you should cut the slots. Once you have them cut, slide the bracket through them and mount them using the factory holes and factory hardware already in the roll bar.

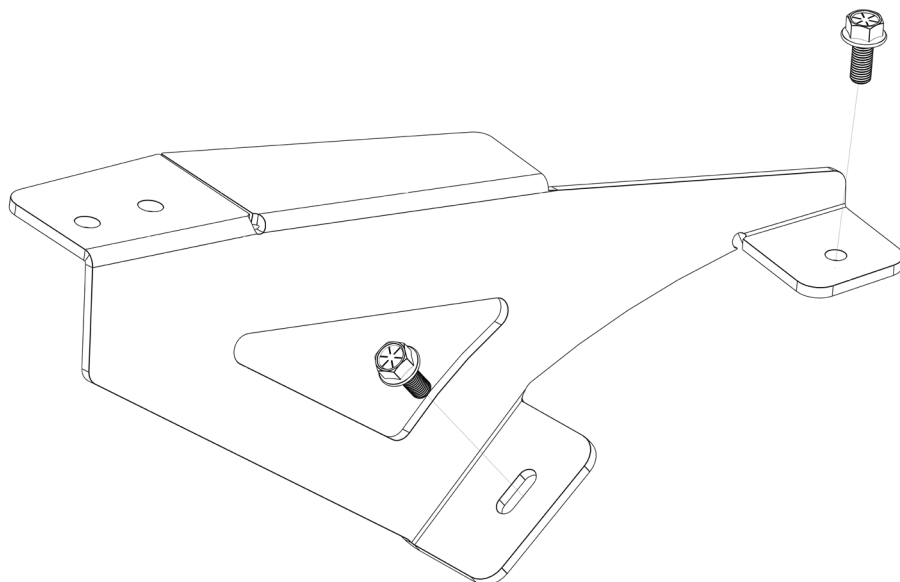
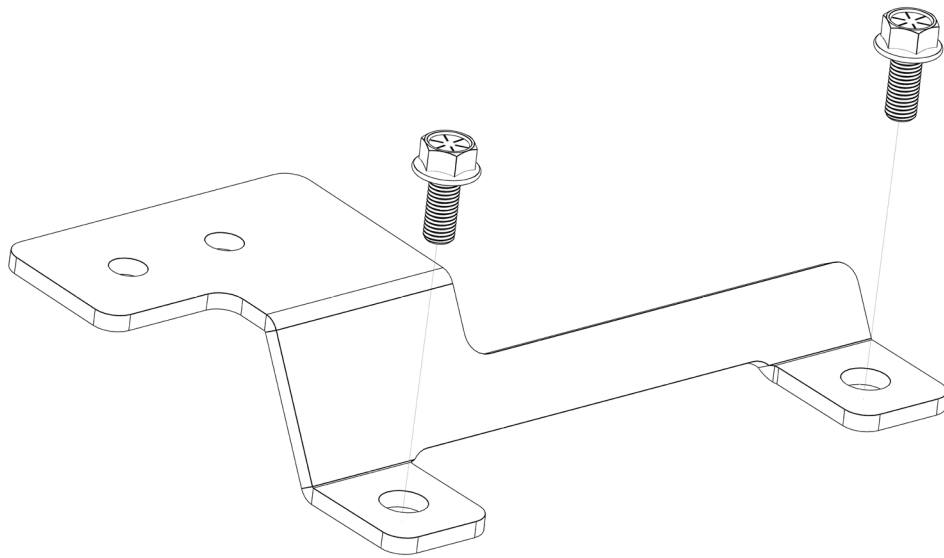

ASSEMBLY

- 6** Next, watch the instruction video for instructions on drilling the holes in your roof. With those drilled, put some RTV around each hole and insert an aluminum spacer into each hole.
- 7** Now that everything is ready, put RTV around the hole in the aluminum spacers and place the assembled rack into position on the roof of the vehicle. It helps to put a bolt through one hole in one of the rear mounts in order to get the rack into the correct position. Make sure that both front mounts are seated firmly in the rain gutters.
- 8** Next, attach the mounts to the roof of the vehicle. Start by putting more RTV around and over each of the mounting holes so that the bolts will have to pass through it. Then, bolt the rack into the roof using the 3/8"-16 X 1-3/4" hex head bolts and 5/16" USS washers on the top of the vehicle and the 3/8"-16 serr. flange nuts on the inside.

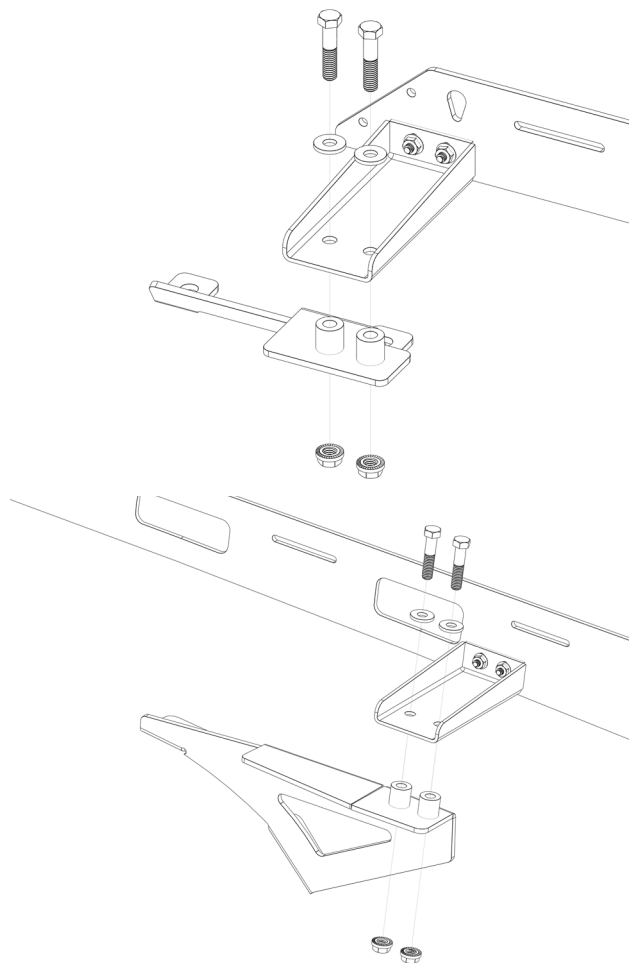

ASSEMBLY

- 9** With everything roughly in place, make any adjustments to the mounts that are necessary to get an equal gap between the bottom of the side rails and the vehicle down the length of the roof and tighten them fully against the side rails.
- 10** Finally, push the front and rear fairing down tight to the roof of the vehicle and tighten everything fully into place. We recommend applying clear 3M paint protection film to the roof of the vehicle anywhere the edge trim/ fairings make contact with the roof. This will protect the paint from dirt/ debris over time.

DIMENSIONS

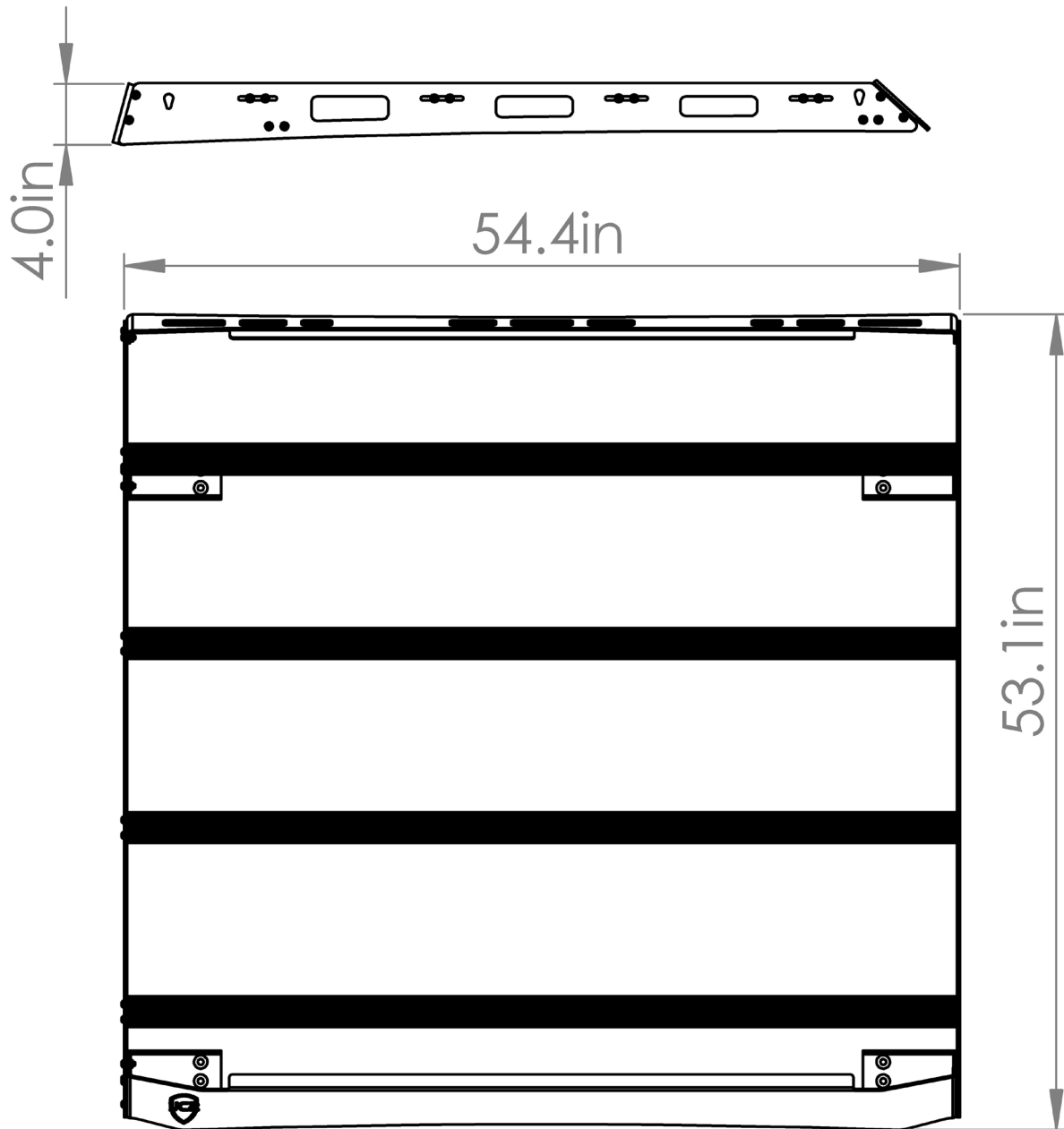



JEEP WRANGLER JK 2 DOOR ROOF RACK

INSTALL INSTRUCTIONS

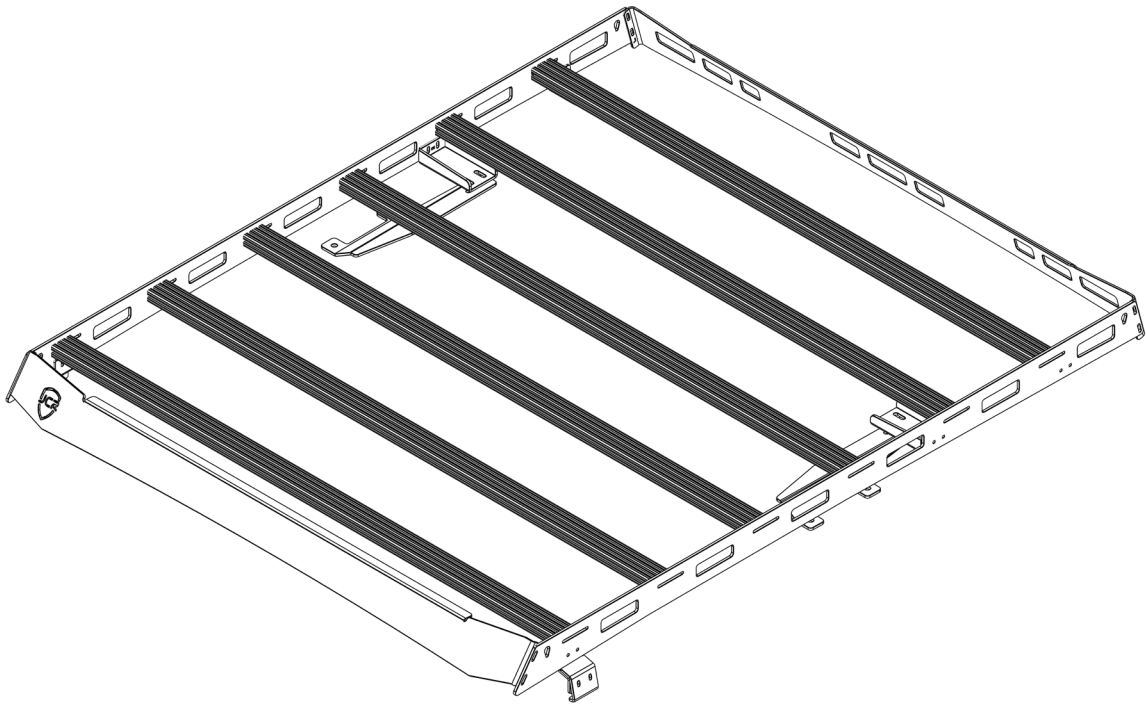

Please read the mounting instructions below carefully before attempting to install.

Check out the install video on the product page for factory rack disassembly.

Thank you for purchasing from JcROffroad! Checkout our website, www.jcroffroad.com for other great off-road products. Be sure to rate and review our product online. If you have any questions or are missing parts, please don't hesitate to call us at 269-353-1184!

INCLUDED HARDWARE

INCLUDED BOLT PACK(S) 046-0052, 045-0134

Note: Some Victory 4x4/JCR Offroad/SquatchProof products share hardware kits. Any extra hardware you may receive that is not listed above can be repurposed or discarded.

58x

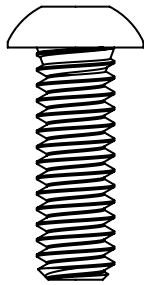

1/4"-20 X 3/4"
Button Head

8x

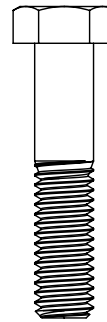

3/8"-16 X 1-3/4"
Hex Head

22x

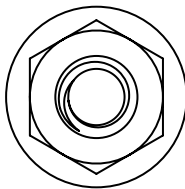

1/4"-20
Serr. Flange Nut

8x

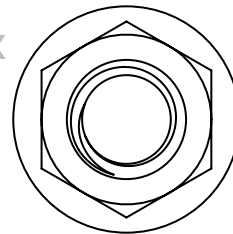

3/8"-16
Serr. Flange Nut

58x

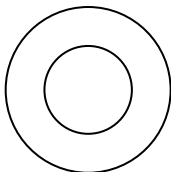

1/4" ID
Washer

8x

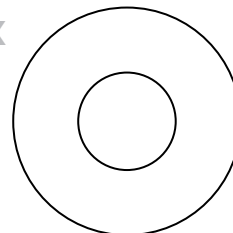

5/16"
USS Washer

4x

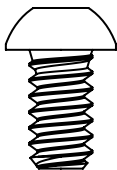

1/4"-20 X 3/8"
Button Head
Included with light
bar cutout option.

8x

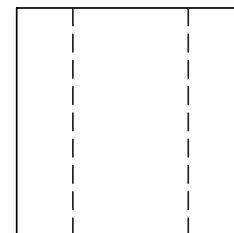

3/8" ID X 3/4"
Aluminum Unthreaded
Spacer

4x

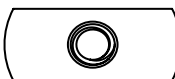

1/4"-20
T-Nut
Included with light
bar cutout option.

4x

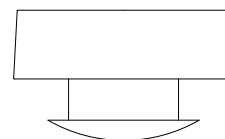

1/2" Push-in Rubber
Bumper

INCLUDED PARTS

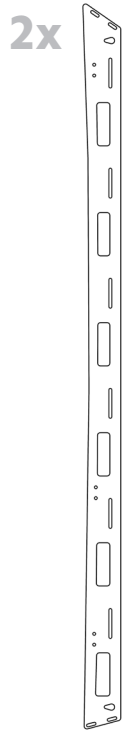

Side Fairings

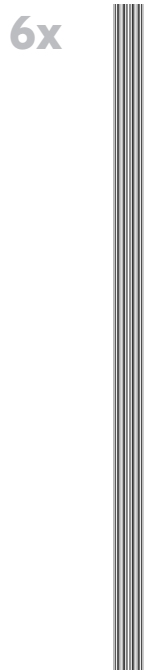

Crossbars

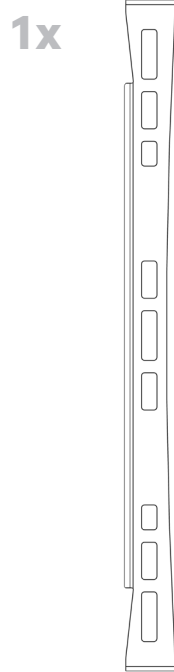

Rear Fairing

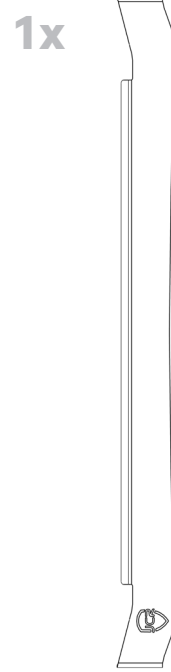

Front Fairing

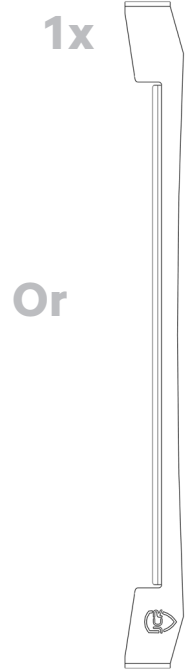

Or

Front Fairing for Light Bar

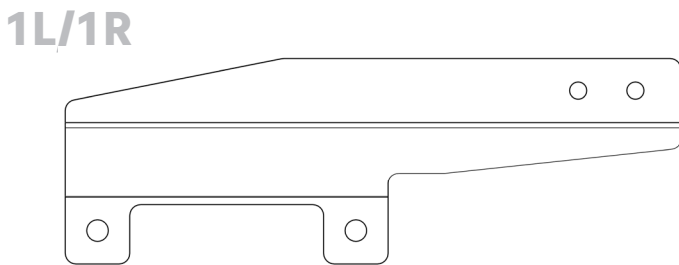

Mid Lower Mount

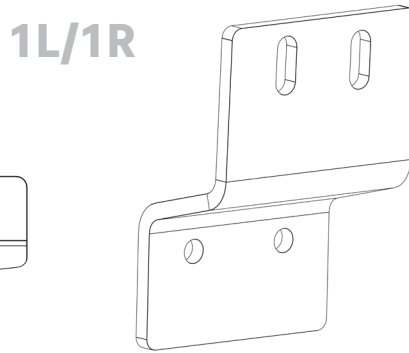

Front Inner Clamp

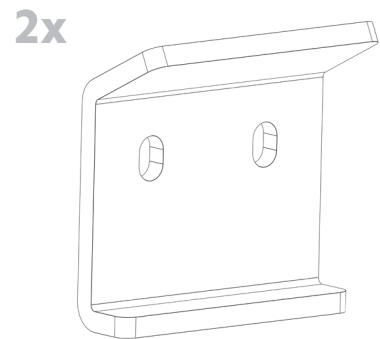

Front Outer Clamp

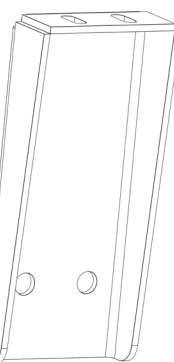
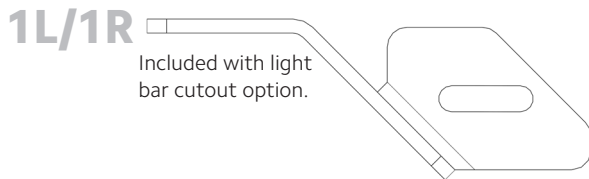

Mid Upper Mount

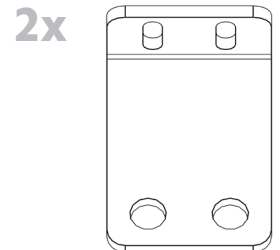

Rear Mount

ASSEMBLY

1. Assemble the rack on the ground. Start by mounting the crossbars between the 2 side rails. For this, use the provided 1/4"-20 x 3/4" button heads and the 1/4" washers (2 per bar, per side). Make sure the machined slot in the rail of the crossbar is facing up so that you can easily add T-nuts to mount your gear. You will also need to apply anti-seize to each bolt at this time.

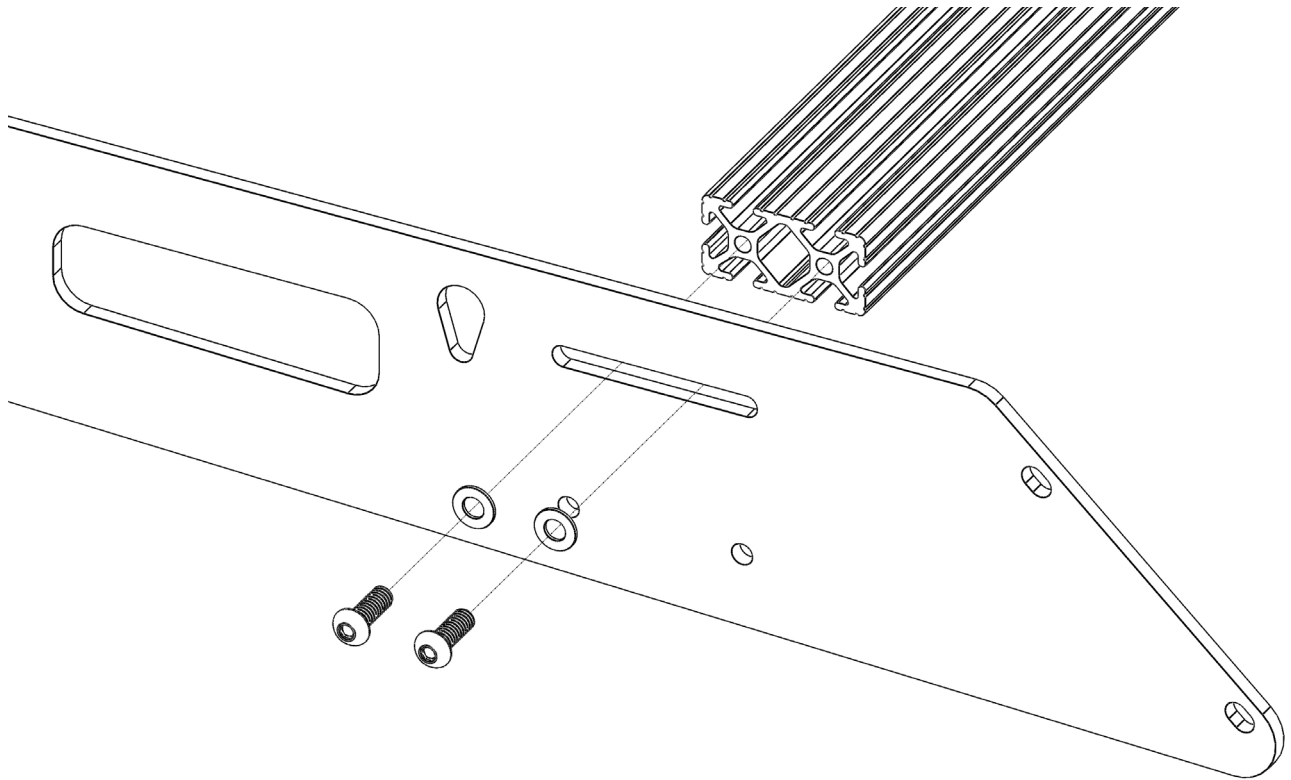

ASSEMBLY

2. Next, mount the strip of the provided edge trim to the bottom edge of the front fairing. Start just to the outside of the peak of the bottom edge and continue until it reaches the equivalent point on the other side of the fairing. Cut off any extra. Then, cut the extra in half and mount the 2 pieces onto the bottom edge of the rear fairing where it contacts the roof of the vehicle.

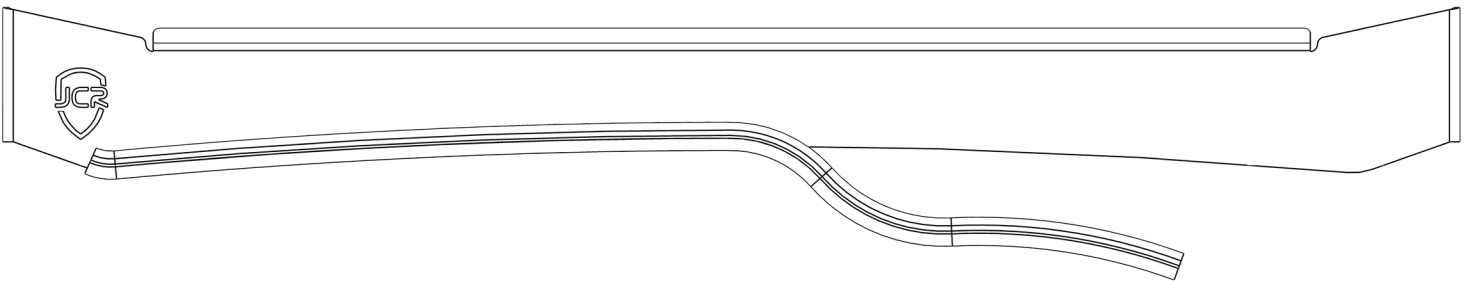

ASSEMBLY

3. Next, mount the front and rear fairings. To do this, use the 1/4"-20 x 3/4" button heads, 1/4" washers, and flange nuts. The front fairing will need (2) of each per side and the rear fairing will also need (2) of each per side. When mounting the front fairing, adjust it all the way up to avoid contact with the roof and leave the bolts loose enough to be able to make adjustments once it is on the vehicle.

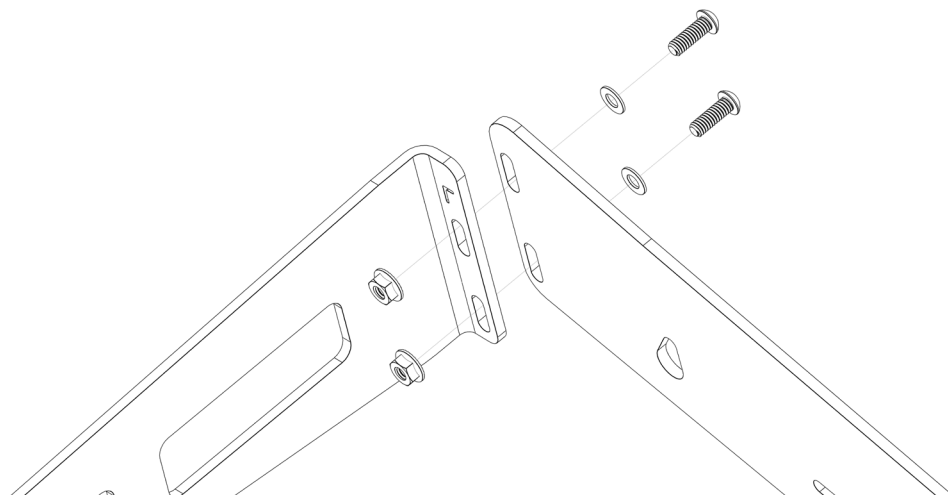
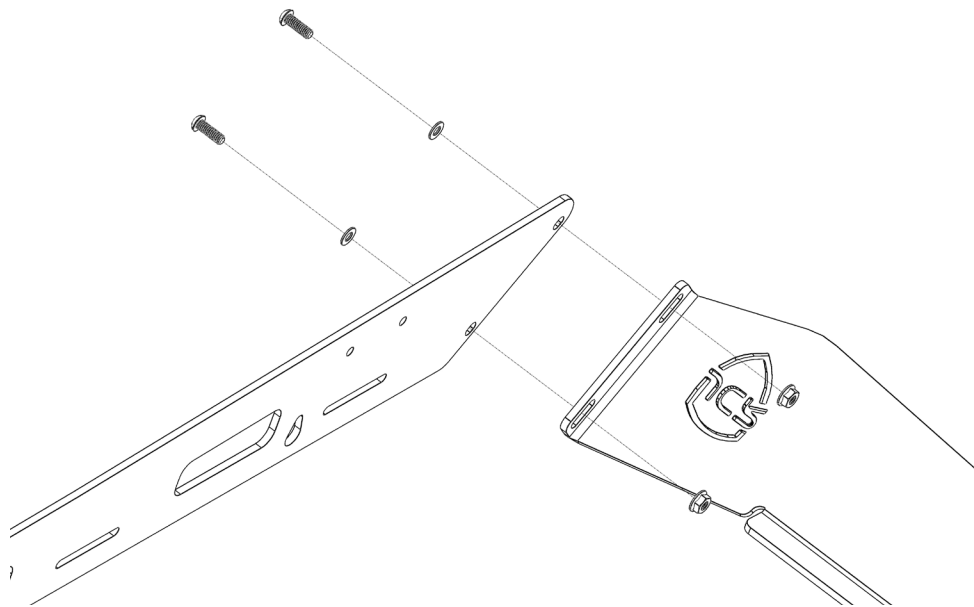

ASSEMBLY

4. You now will need to remove your hardtop in order to cut slots in your roll bar padding to be able to slide the mounting bracket through and bolt to the roll bar while still being able to use the zipper. Unzip the zipper of the sport bar covers to expose two bolts behind the front seats as shown on the 4-door model in the picture (the bolts are in the same location on a 2-door). Make two slits in the sport bar covers about 1" below the zipper on the inboard side, long just enough to allow the tabs of the bracket to go through. Orient the bracket so that the holes mounting it to the sport bar are at the front and outboard side (as shown below), push the tabs of the bracket through the slits in the sport bar cover, secure with the factory hardware, and zip up the zipper of the sport bar cover.

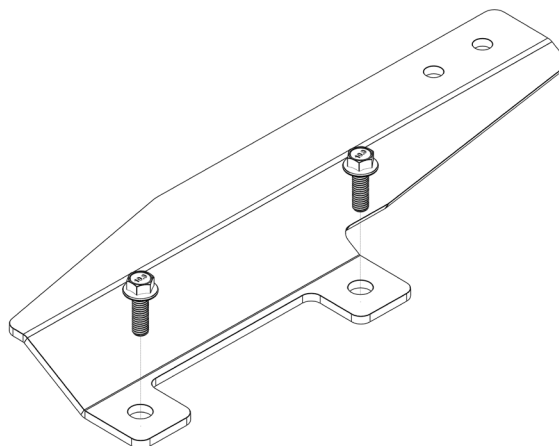

ASSEMBLY

5. Now take the (2) provided rear mounts and the (4) provided rubber bumpers and insert the bumpers through the holes in the mounts, as shown in the orientation below.

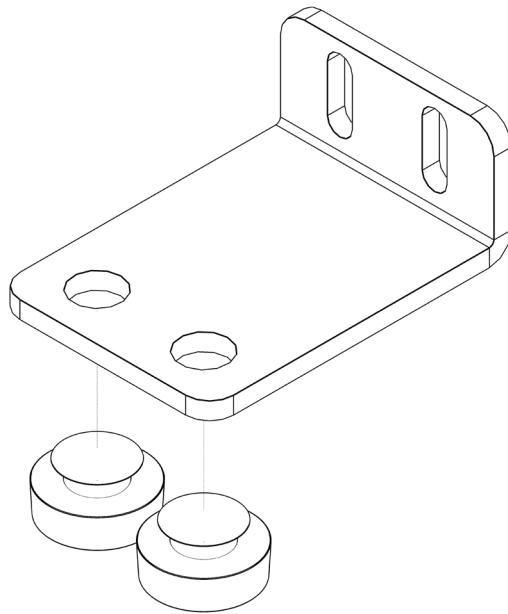

ASSEMBLY

- Next, attach the (6) provided mounts to the assembled roof rack using (2) of the provided 1/4"-20 x 3/4" button heads, 1/4" washers and flange nuts per mount on each side. Set the mounts at the lowest position on the slots and tighten them for now to give the most clearance.

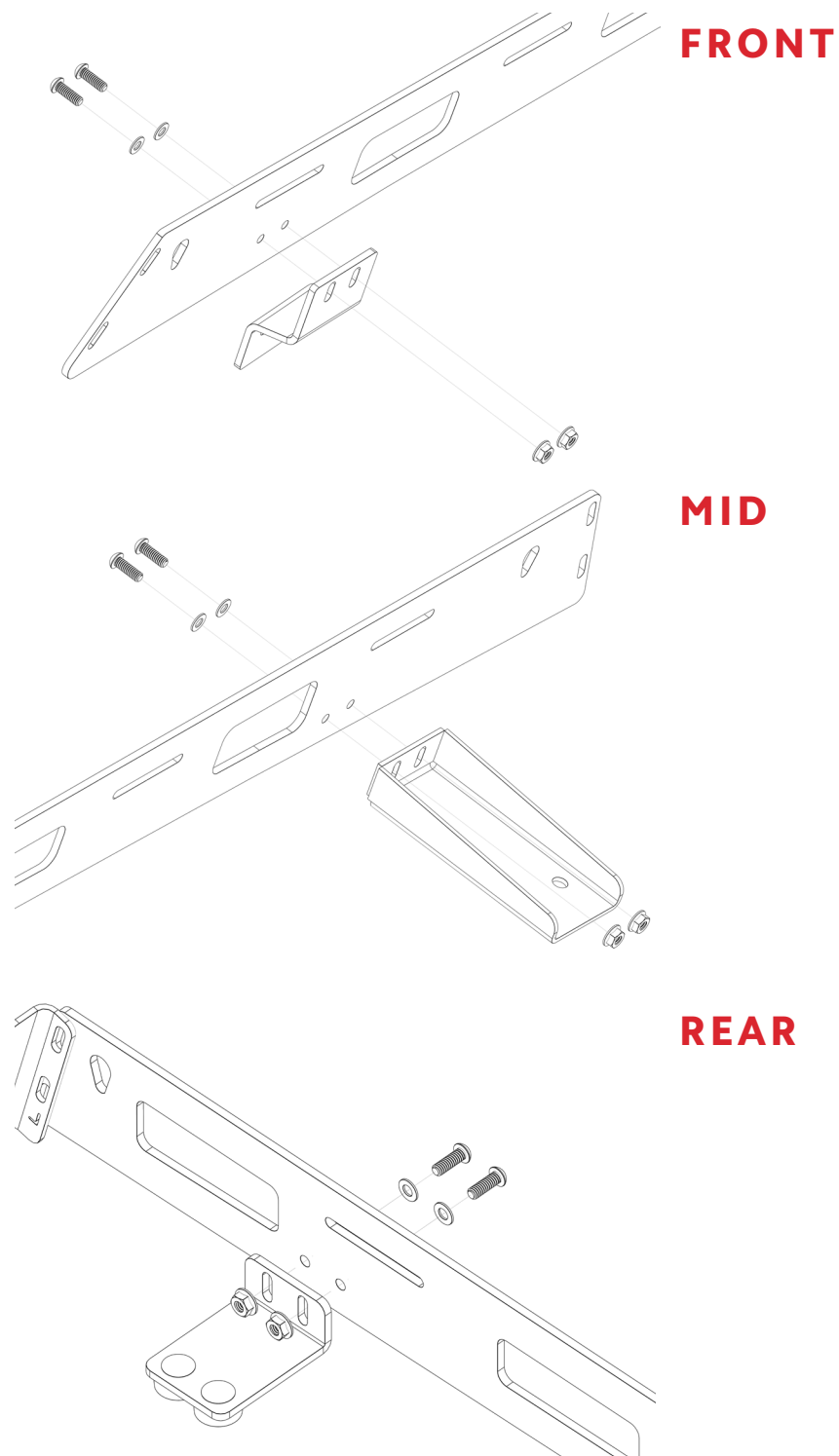

ASSEMBLY

- 7.** Next, you will need to place the hardtop back on your Jeep so you can drill your holes to mount the rack. With the hardtop in place, use a 3/8" drill bit to drill your (4) holes up from the inside of the vehicle using the holes in the installed brackets as a guide. Be sure to keep your drill as straight as possible. With the holes drilled, make sure to apply some RTV sealant around each hole and insert a provided aluminum spacer into each hole from the top to rest on the brackets.
- 8.** Now that everything is ready, apply more RTV around the hole in the aluminum spacers and place the assembled rack into position on the roof of the vehicle. Make sure that both front mounts are seated firmly in the rain gutters on the freedom panels.
- 9.** Next, attach both of the mid mounts to the roof of the vehicle. Start by putting more RTV in and around each of the mounting holes so that the bolts will have to pass through it. Then, bolt the rack into the roof using the 3/8"-16 x 1-3/4" hex heads and 5/16" washers on the top of the vehicle and the 3/8"-16 flange nuts on the inside. The rear mount will just rest on top of the roof with the rubber bumpers.

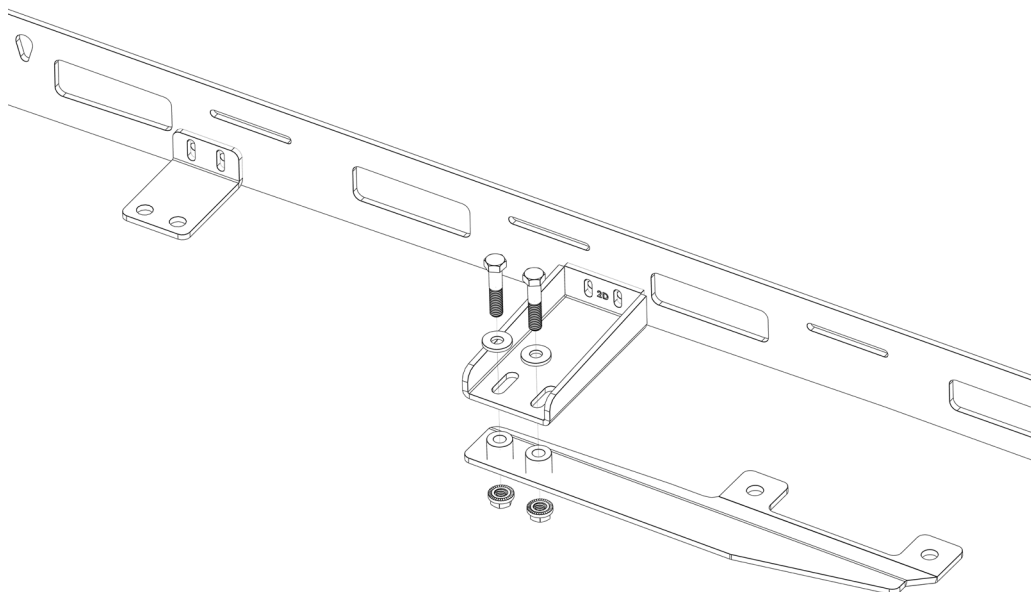

ASSEMBLY

- 10.** Clamp the front mount into place using the (2) provided "C" shaped brackets. Place the clamp bracket over the front mount so that the larger flange is over the top of the mount and the smaller flange is under the bottom of the rain gutter. Then, clamp it firmly into place using the provided 1/4"-20 x 3/4" button heads, 1/4" washers, and flange nuts.

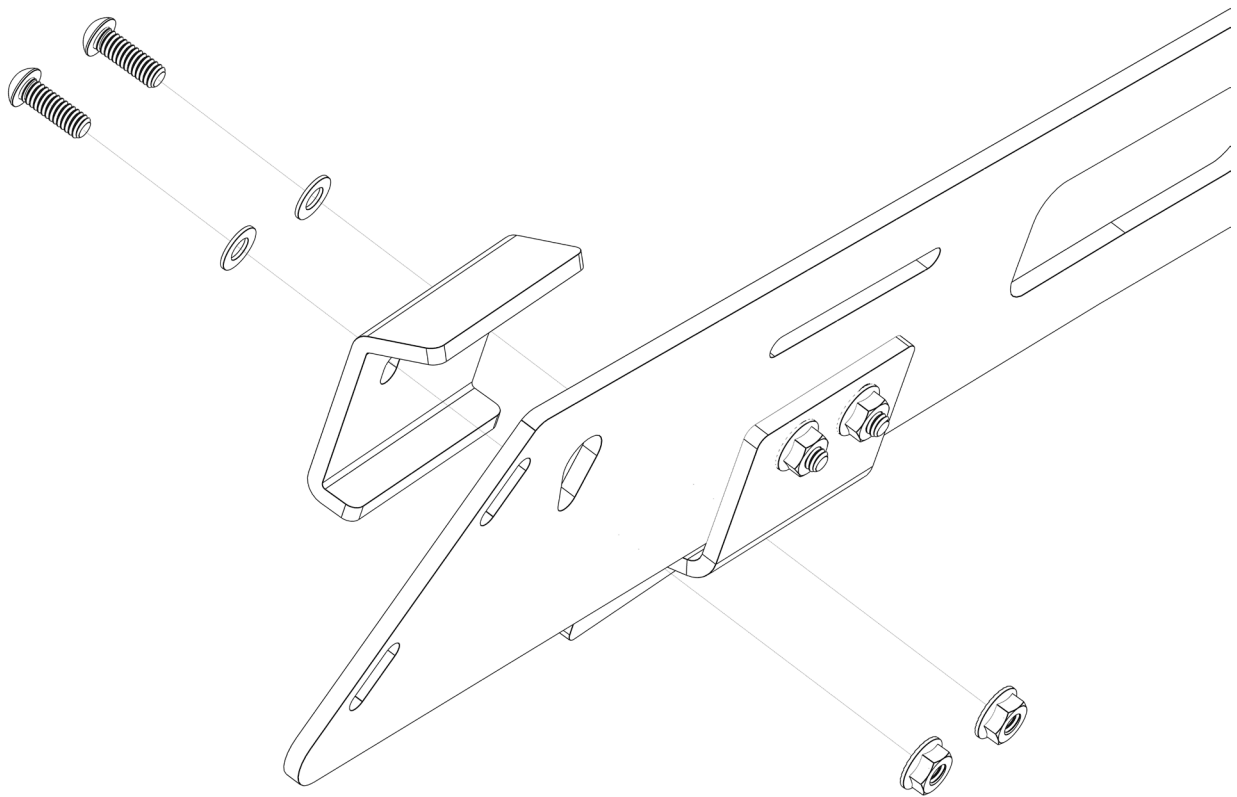

- 11.** With everything roughly in place, make any adjustments to the mounts that are necessary to get an equal gap between the bottom of the side rails and the vehicle down the length of the roof and tighten them fully against the side rails.
- 12.** Finally, push the front and rear fairing down tight to the roof of the vehicle and tighten everything fully into place. We recommend applying clear 3M paint protection film to the roof of the vehicle anywhere the edge trim/ fairings make contact with the roof. This will protect the paint from dirt/ debris over time.

ASSEMBLY

13. Once your rack is positioned how you like it, make sure to tighten down all of your hardware to complete your install. That's it! Now you are ready to mount additional gear or secure cargo securely onto the roof of your 2 door Wrangler JK. Please visit www.jcroffroad.com for other great made-in-the-US gear for your Jeep.



40" LIGHT BAR ASSEMBLY

1. Slide 2 T-nuts into each of the channels on the top side of the front-most crossbar using the slots. Then, place each light bar mount over one pair of T-nuts and loosely bolt it in place using the 1/4"-20 X 3/8" button heads.

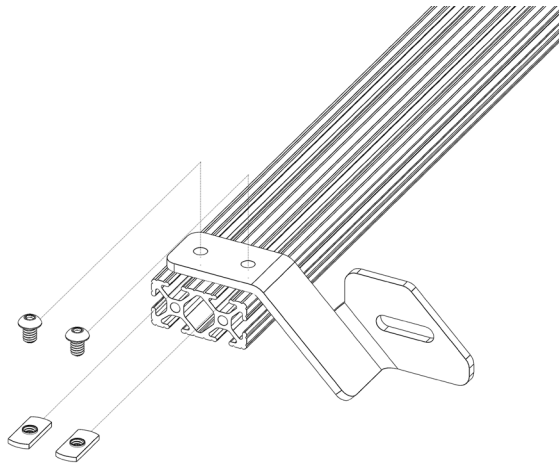

2. Next, place your light bar between the mounts and mount it in the slots using the hardware provided with the light bar. After that is firmly in position, make any adjustments to the positioning necessary to center the light bar on the rack. Depending on the rack and light bar, you may need to adjust the position of the cross bar in its slot as well.

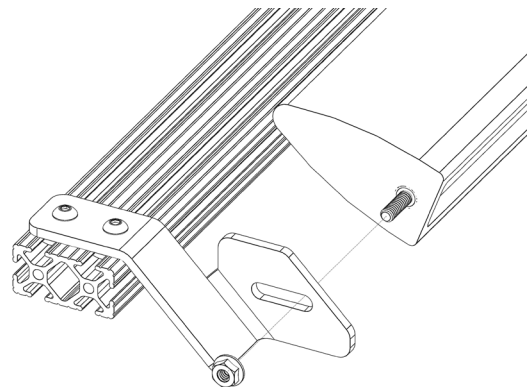

DIMENSIONS

