

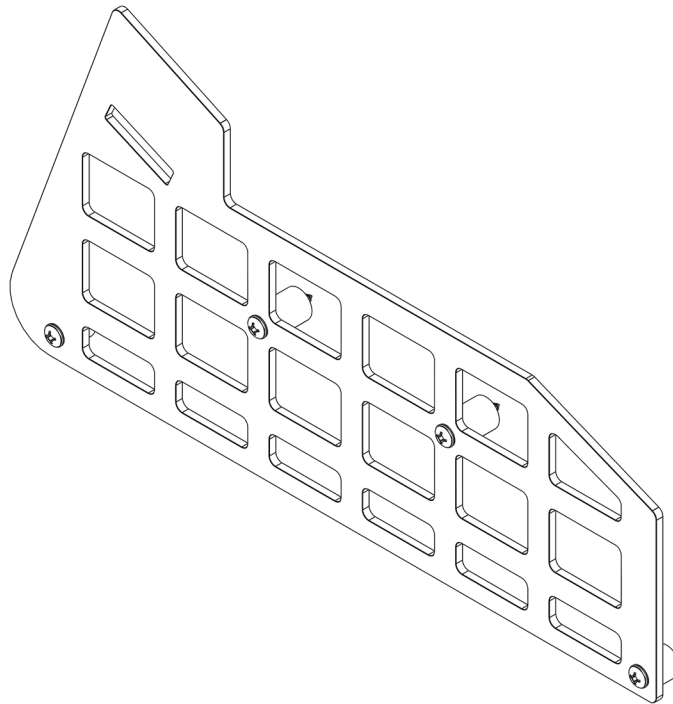

4TH GEN RANGER CENTER CONSOLE MOLLE PANEL

INSTALL INSTRUCTIONS



Please read the mounting instructions below carefully before attempting to install.

Be sure to check out the install video on the product page, if available.

Thank you for purchasing from JcROffroad! Checkout our website, www.jcroffroad.com for other great off-road products. Be sure to rate and review our product online. If you have any questions or are missing parts, please don't hesitate to call us at 269-353-1184!

INCLUDED HARDWARE

4x



.257" ID X .500" OD X .375"
Nylon Spacer

4x

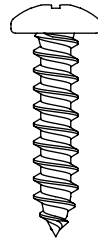

8-15 X 3/4" PAN PHIL
Button Head

4x

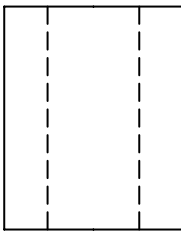

.257" ID X .500" OD X .625"
Nylon Spacer

4x

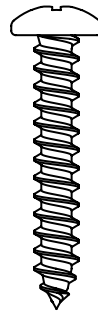

8-15 X 1" PAN PHIL
Button Head

INCLUDED PARTS

2x

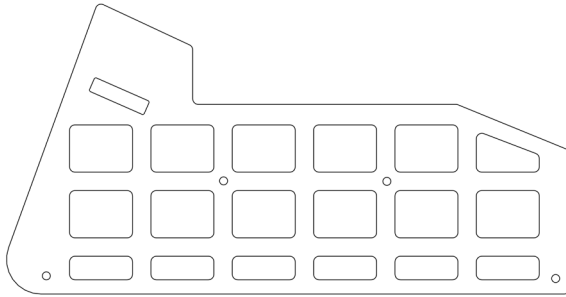

ASSEMBLY

- 1** Move your seat all the way back. Place the bottom edge of the panel on the edge of the seam running horizontally across the side of the center console. Then, find where that seam runs into another under the dash and makes sort of a T shaped junction. Measure back 5" from that junction on the driver's side or 5.5" on the passenger's side. This is where the front most mounting hole in the panel should go.
- 2** Once the panel has been located, make a hole in the center console at each mounting hole in the panel using either a 1/8" drill bit, or a pick. Only drill deep enough to get the screws started, it is not necessary to drill all the way through. This will prevent any possibility of damaging anything behind the console. Then, install the panel using a Phillips screwdriver. Use 1 screw and 1 spacer per hole. The middle two holes get the longer spacers and screws

