

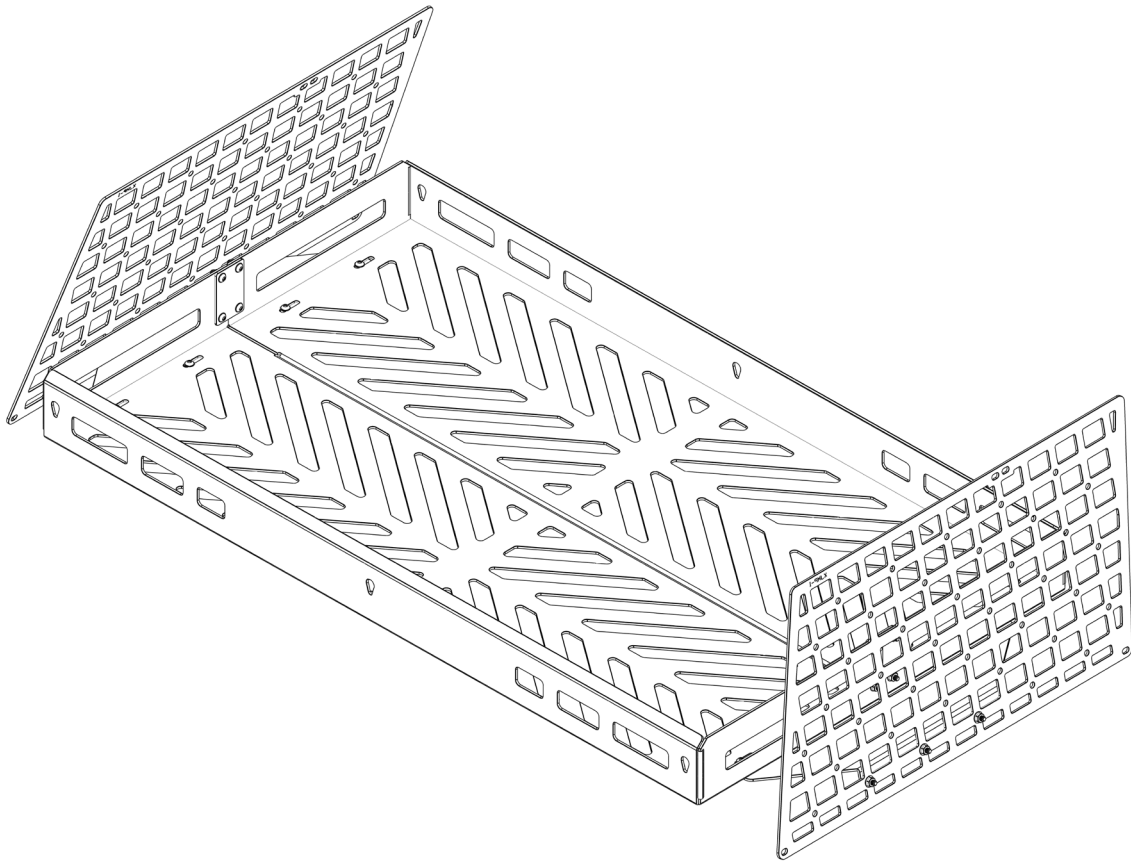

XJ INTERIOR CARGO BASKET

INSTALL INSTRUCTIONS



Please read the mounting instructions below carefully before attempting to install.

Be sure to check out the install video on the product page, if available.

Thank you for purchasing from Victory 4x4! Checkout our website, victory4x4.com for other great off-road products. Be sure to rate and review our product online. If you have any questions or are missing parts, please don't hesitate to call us at 269-459-8447!

INCLUDED HARDWARE

25x

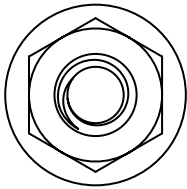

1/4"-20
Serr. Flange Nut

25x

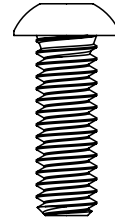

1/4"-20 X 3/4"
Button Head

25x

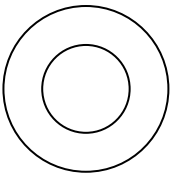

1/4" ID
Washer

INCLUDED PARTS

2x

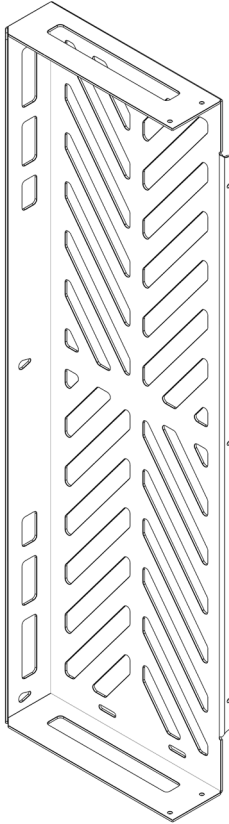

2x

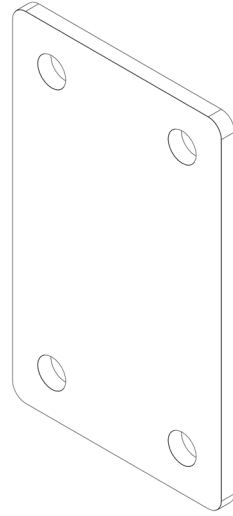

2x

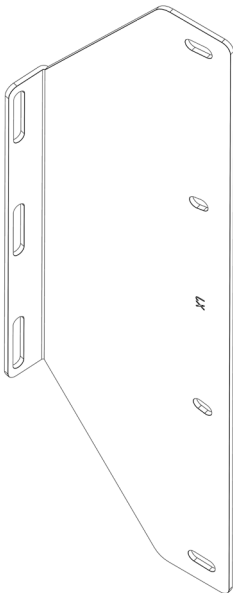

INSTALLATION

- 1 Start by loosely installing the mounts onto the Rear Window MOLLE Panels. Do this using three 1/4"-20 X 3/4" button head bolts, 1/4" washers and 1/4"-20 serr. flange nuts per mount. They should be mounted on the first row of holes and the first slot in each mount should line up with the second hole away from the hatch of the vehicle. Either mount can be used on either side.

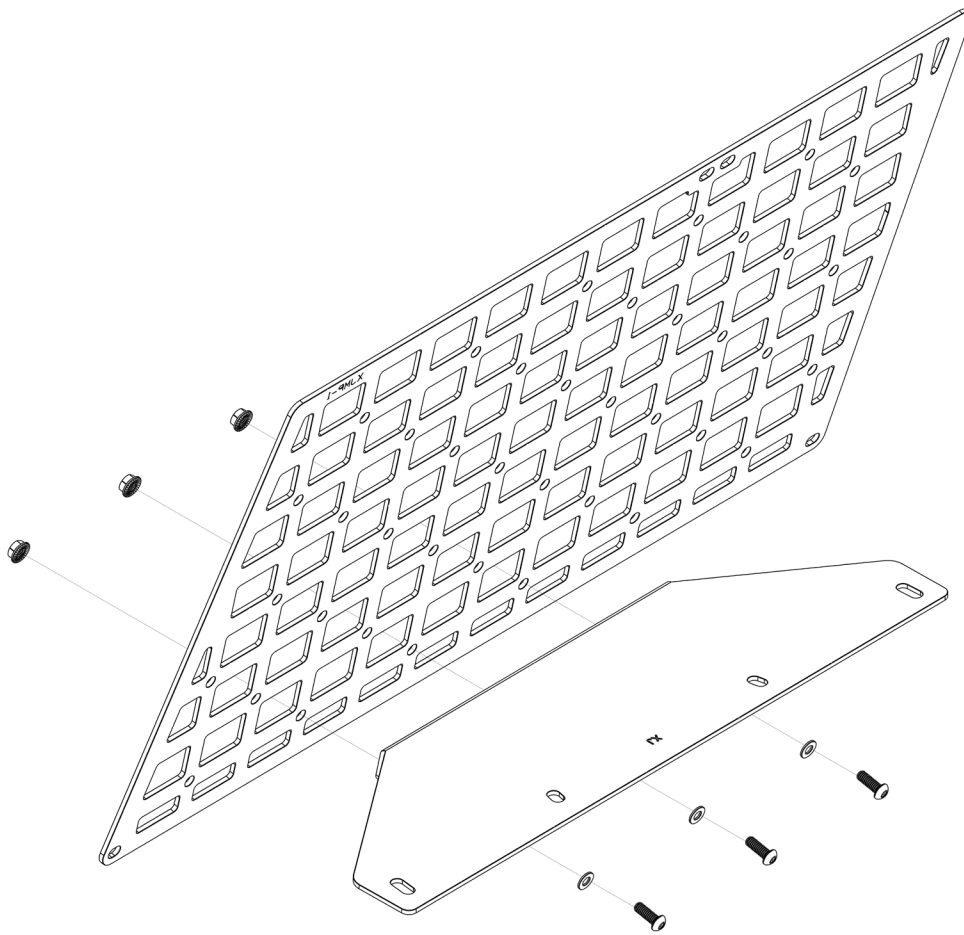

INSTALLATION

- 2** Next, assemble the basket. Start by using three 1/4"-20 X 3/4" button head bolts, 1/4" washers and 1/4"-20 serr. flange nuts to loosely attach the bottom flange of each half of the basket to each other.

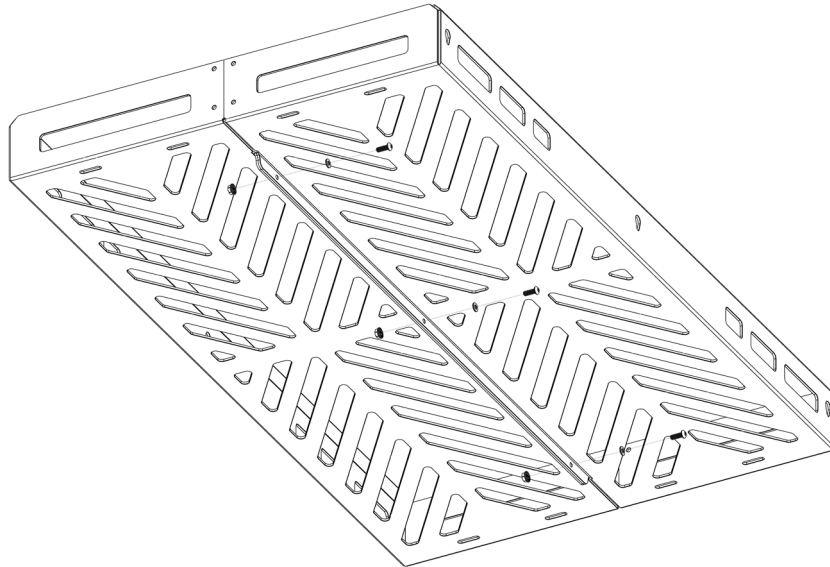

- 3** Next, use the small rectangular brackets along with four 1/4"-20 X 3/4" button head bolts, 1/4" washers and 1/4"-20 serr. flange nuts per side to secure the sides of the basket loosely together. Once everything is in place, go back and fully tighten all of the bolts on the basket.

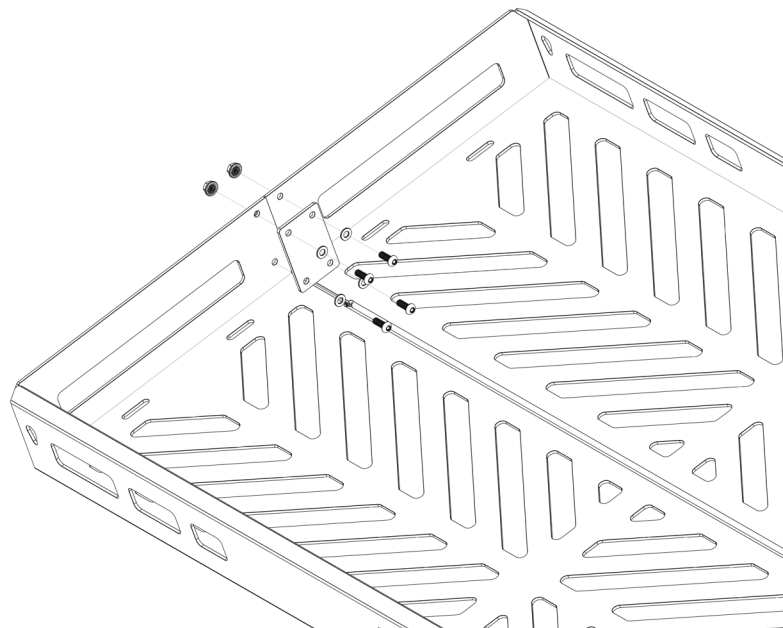

INSTALLATION

- 4 Next, cut the provided trim into 3" strips. Then, using something that will not damage the powder coat on the basket, pry the corners apart just enough to put the trim on edge of the side panel. Do this at each corner.

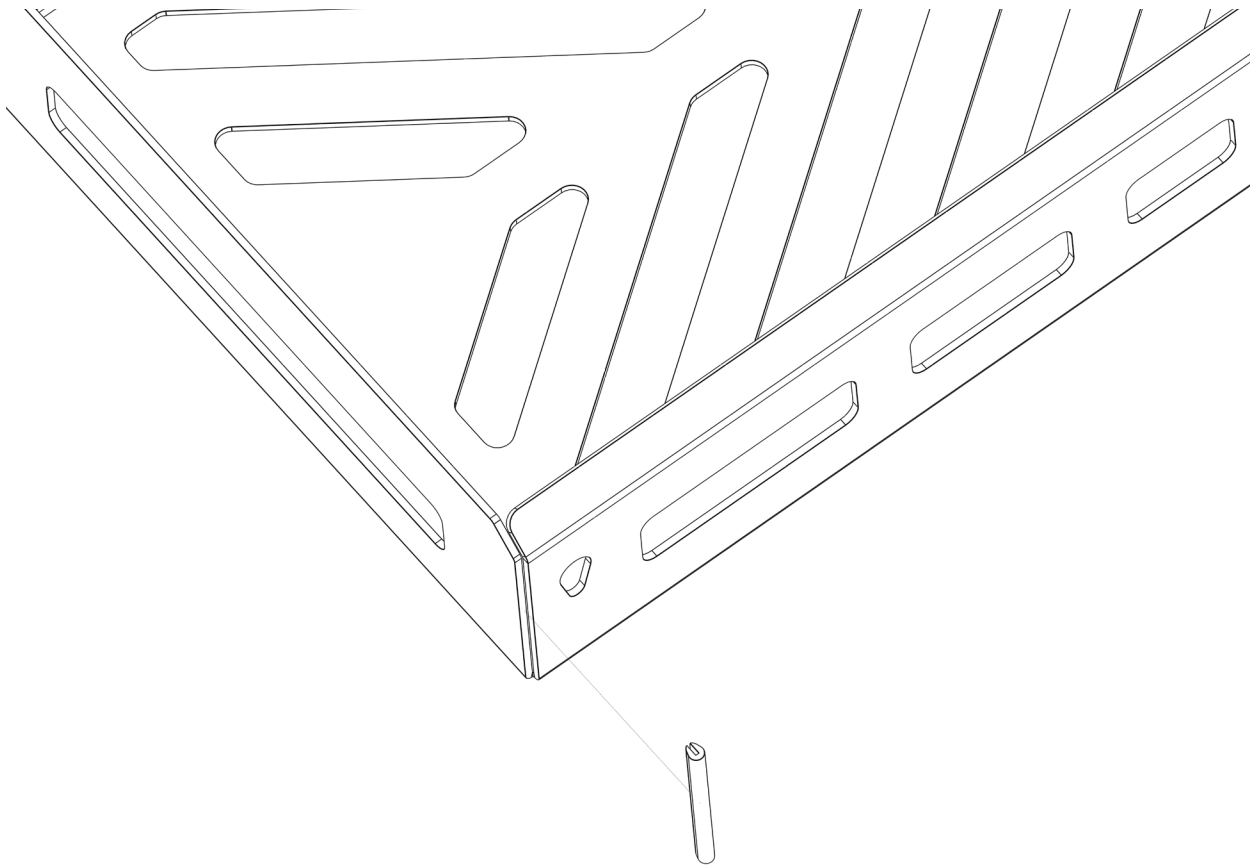

INSTALLATION

- 5 With the basket fully assembled, place it on top of the mounts and loosely bolt it in using four 1/4"-20 X 3/4" button head bolts, 1/4" washers and 1/4"-20 serr. flange nuts per side. Once it is loosely installed, adjust the position of the basket until it is where you want it, then finish tightening everything fully into place.

